

THIS DOCUMENT PROPRIETARY TO TITAN AIRCRAFT, AND IS NOT TO BE USED, CIRCULATED, REPRODUCED, COPIED, OR DISCLOSED IN ANY MANNER WITHOUT PRIOR WRITTEN PERMISSION OF AN AUTHORIZED OFFICIAL OF TITAN AIRCRAFT.

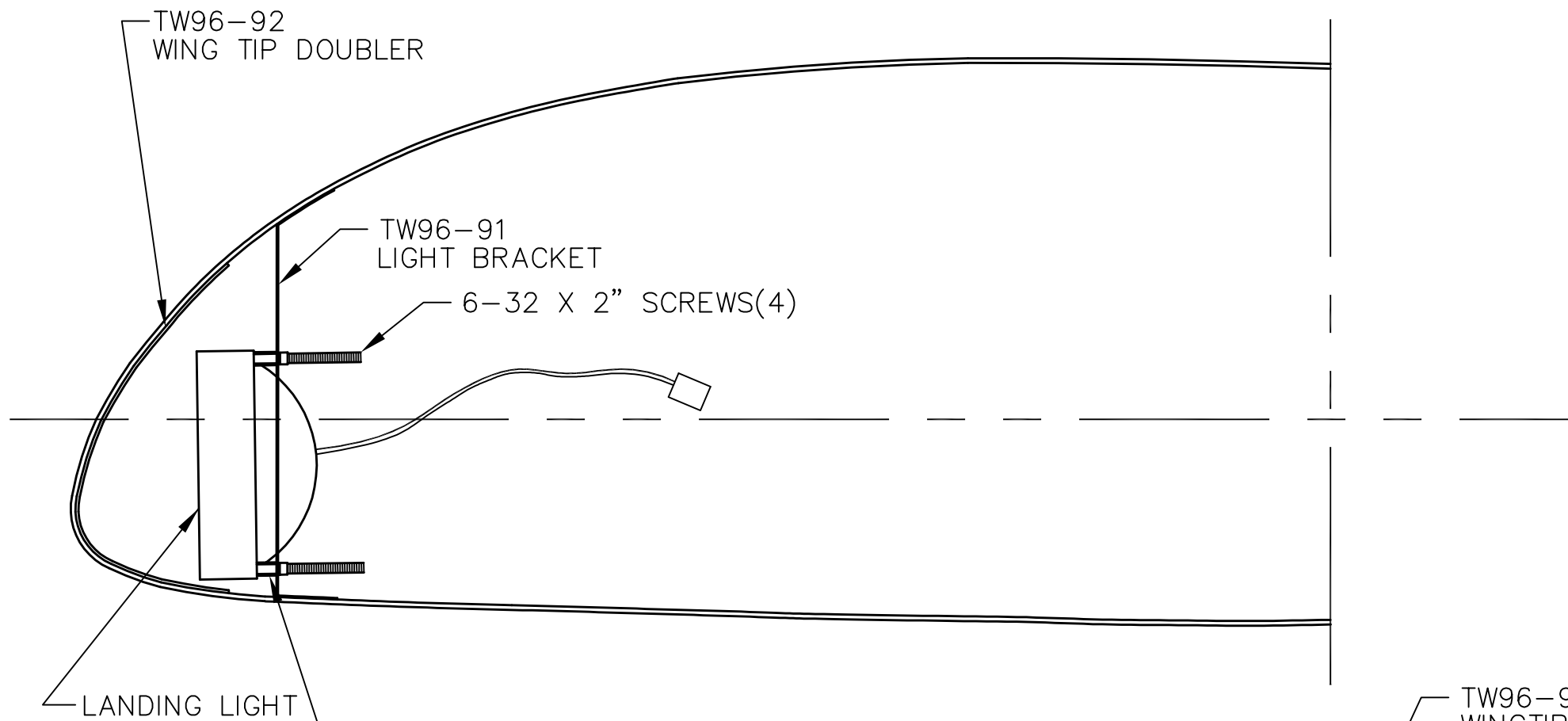

NOTES:

- PRE-ASSEMBLE ALL PARTS AND PLACE IN POSITION. DISASSEMBLE.
- USE TW96-95 LENS ASSEMBLY TO LAY OUT HOLE FOR LENS TO SIT IN.
- CUT UNDERSIZED AND CONTINUE REMOVING MATERIAL UNTIL THE LENS RESTS SNUGGLY IN THE LEADING EDGE OF THE WING TIP.
- ASSEMBLE LENS AND TW96-92 WING TIP DOUBLER, PLACE IN POSITION AND DRILL WING TIP AND DOUBLER WITH #30(.1285 DIA.) DRILL. FASTEN WITH CLECO'S.
- ATTACH LIGHT TO TW96-91 LIGHT BRACKET AND FIT WING TIP, CUT TW96-96 SPACERS TO GAIN DESIRED ANGLE OF LIGHT.
- DRILL WING TIP AND BRACKET WITH #30(.1285 DIA.) DRILL. FASTEN WITH CLECO'S.
- PERMANENTLY ASSEMBLE WITH AD42BS RIVETS.

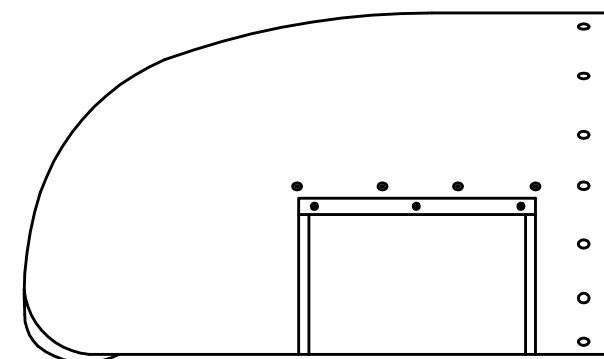

6-32 X 1/2" SCREWS(6)
(CUT SHORTER IF NEEDED)

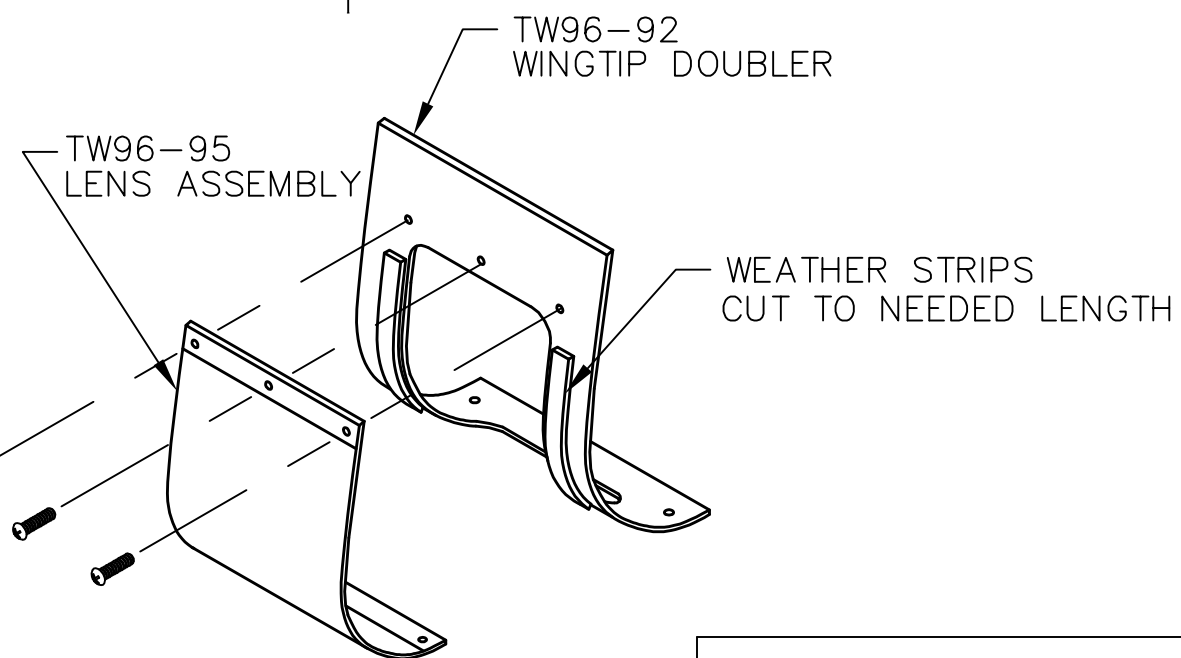

TITAN AIRCRAFT	TITAN AIRCRAFT SUPPLY 1419 STATE ROUTE 45 SOUTH AUSTINBURG, OHIO 44010
--------------------------	---

DETAIL NAME		SCALE N/A		PART NO.	
DRAWN K. BOHRER		DATE 2/26/96		ASSEMBLY NAME WING TIP LANDING LIGHT SYSTEM	
CHECKED B. PASSAFIUME		DATE 6/4/96		PART NO.	
APPROVED J. WILLIAMS		DATE 6/18/96		DRAWING NO. B 96-INS-0654-A	