

THIS DOCUMENT PROPRIETARY TO TITAN AIRCRAFT, AND IS NOT TO BE USED, CIRCULATED, REPRODUCED, COPIED, OR DISCLOSED IN ANY MANNER WITHOUT PRIOR WRITTEN PERMISSION OF AN AUTHORIZED OFFICIAL OF TITAN AIRCRAFT.

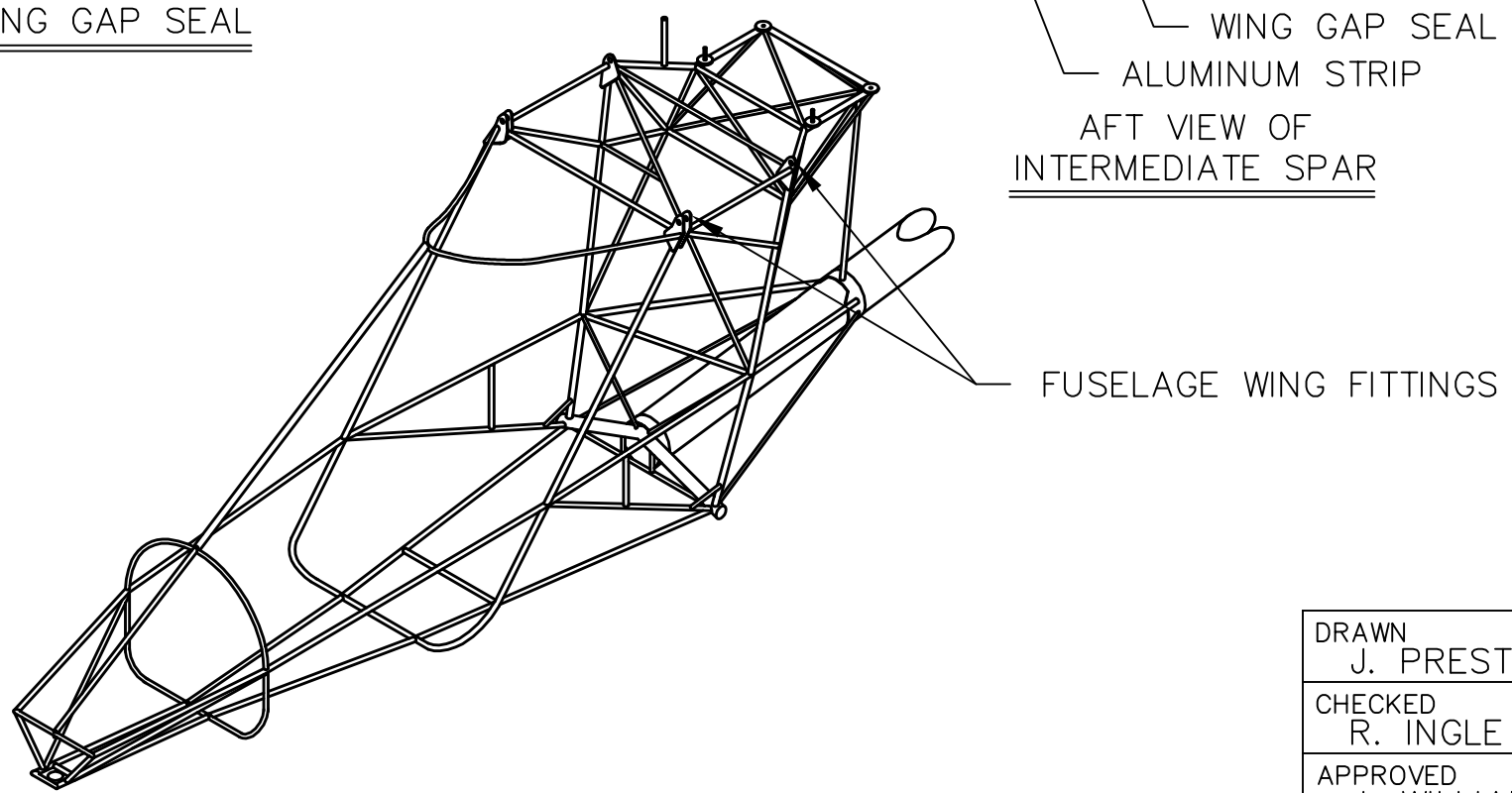
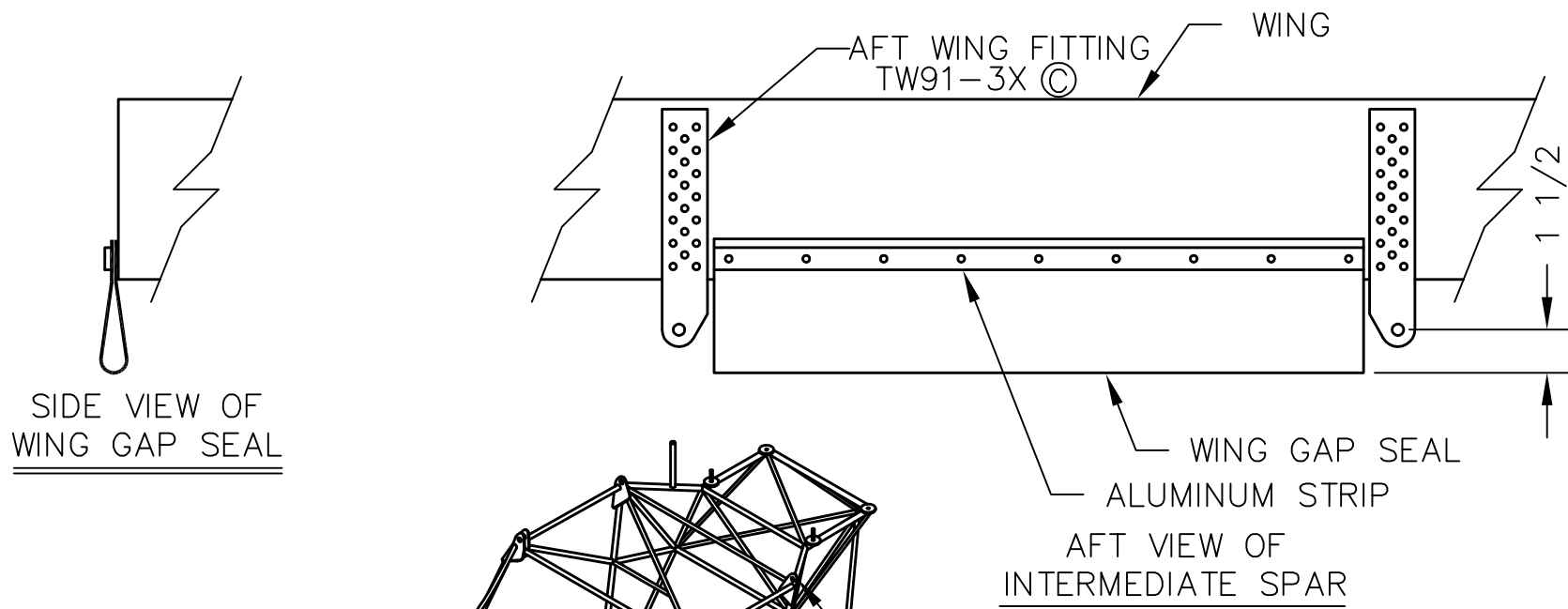
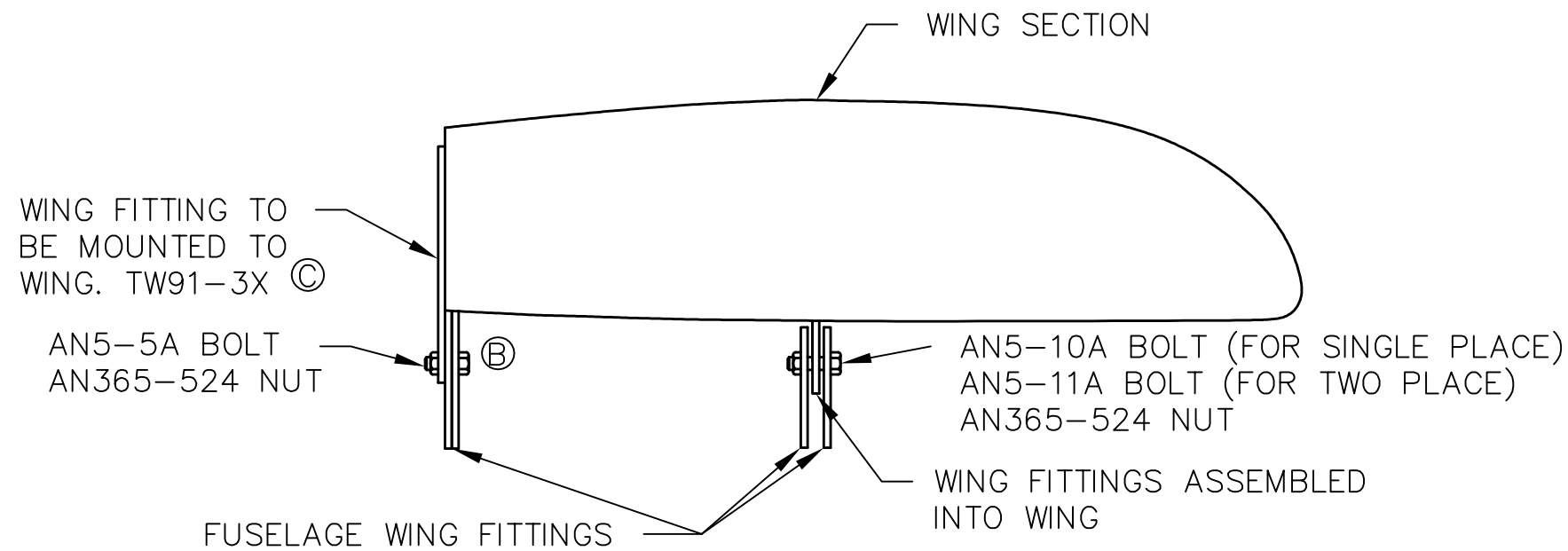

REVISIONS				
E.C. NO.	REV.	DESCRIPTION	BY	DATE
1020	B	AFT FUSELAGE FITTING DOUBLED	K.B.	6/97
1845	C	ADDED PART NUMBERS	KL	3/01

- NOTES:
- ALL DIMENSIONS ARE INCHES.
 - POSITION WING ON TOP OF FUSELAGE SO THAT THE (2) WING FITTINGS FACTORY ASSEMBLED INTO THE WING SLIDE BETWEEN THE FORWARD FUSELAGE WING FITTINGS. THE WING SHOULD REST ON TOP OF THE REAR FUSELAGE WING FITTINGS.
 - BOLT THE FORWARD WING FITTINGS. DO NOT BEND WING FITTINGS BY OVER TIGHTENING THE NUT AND BOLT.
 - BOLT THE (2) UNASSEMBLED WING FITTINGS TO THE REAR FUSELAGE WING FITTINGS.
 - PLACE THE UNASSEMBLED WING FITTINGS IN A VERTICLE POSITION.
 - DRILL MOUNTING HOLES THRU INTERMEDIATE SPAR USING EXISTING HOLES IN WING FITTING AS A GUIDE. DRILL WITH #30 DRILL (.1285 DIA) AND CLECO.
 - RIVET AND BOND WING FITTINGS TO WING. RIVET WITH SD43BS RIVETS (1/8 DIA X 21/64 LONG). BOND WITH URALANE 8089. TO ENSURE THE WING FITTINGS ARE MOUNTED EVEN WITH THE FUSELAGE WING FITTINGS, LEAVE THE WING MOUNTED TO THE FUSELAGE DURING THE RIVETING AND BONDING PROCESS.
 - CUT AN ALUMINUM STRIP APPROXIMATELY 1 INCH WIDE AND LONG ENOUGH TO FIT BETWEEN THE REAR WING FITTINGS.
 - DOUBLE OVER A SECTION OF THE WING GAP SEAL, LONG AND WIDE ENOUGH TO BE POSITIONED AS SHOWN.
 - POSITION WING GAP SEAL AND ALUMINUM STRIP ONTO WING AS SHOWN. DRILL MOUNTING HOLES WITH #30 DRILL (.1285 DIA) THRU ALUMINUM STRIP, WING GAP SEAL AND WING. RIVET WITH AD44ABSLF RIVETS (1/8 DIA X 25/64 LONG).
 - BOLT WING ONTO FUSELAGE.

TITAN AIRCRAFT SUPPLY
 1419 STATE ROUTE 45 SOUTH
 AUSTINBURG, OHIO 44010

DETAIL NAME		MOUNTING WING TO FUSELAGE		
SCALE	N/A	PART NO.		
ASSEMBLY NAME		ALL TORNADO AIRCRAFT		
PART NO.		DRAWING NO.		
DRAWING NO.		B 92-INS-0321-C		

DRAWN	J. PRESTON	DATE	12/7/92
CHECKED	R. INGLE	DATE	3/2/01
APPROVED	J. WILLIAMS	DATE	3/2/01