

THIS DOCUMENT PROPRIETARY TO TITAN AIRCRAFT, AND IS NOT TO BE USED, CIRCULATED, REPRODUCED, COPIED, OR DISCLOSED IN ANY MANNER WITHOUT PRIOR WRITTEN PERMISSION OF AN AUTHORIZED OFFICIAL OF TITAN AIRCRAFT.

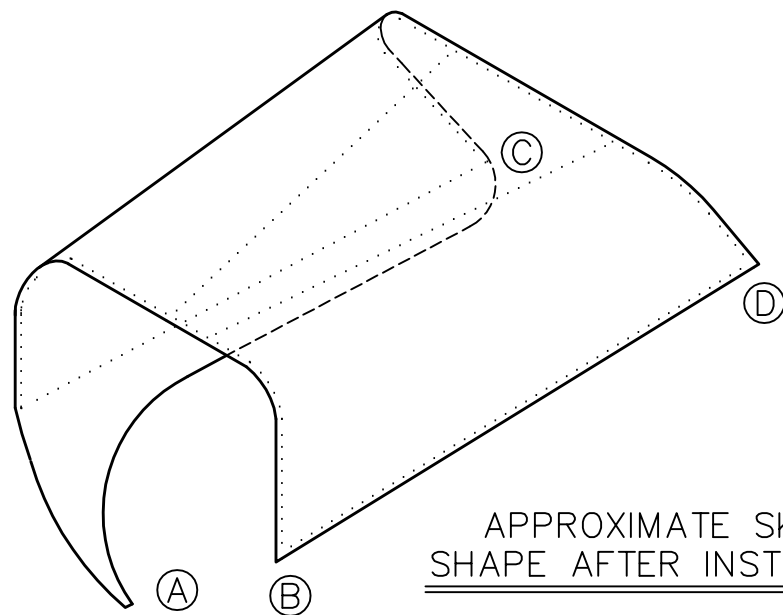

APPROXIMATE SKIN SHAPE AFTER INSTALLED.

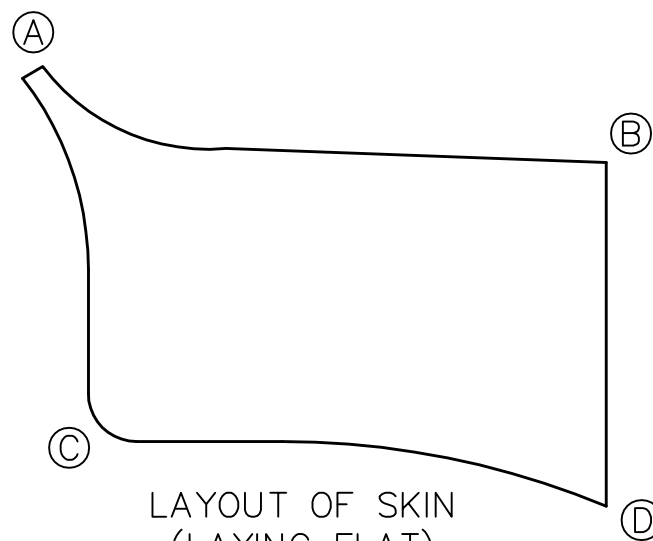

LAYOUT OF SKIN (LAYING FLAT)

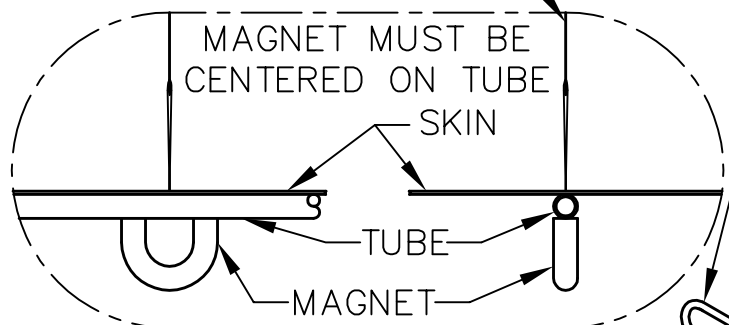
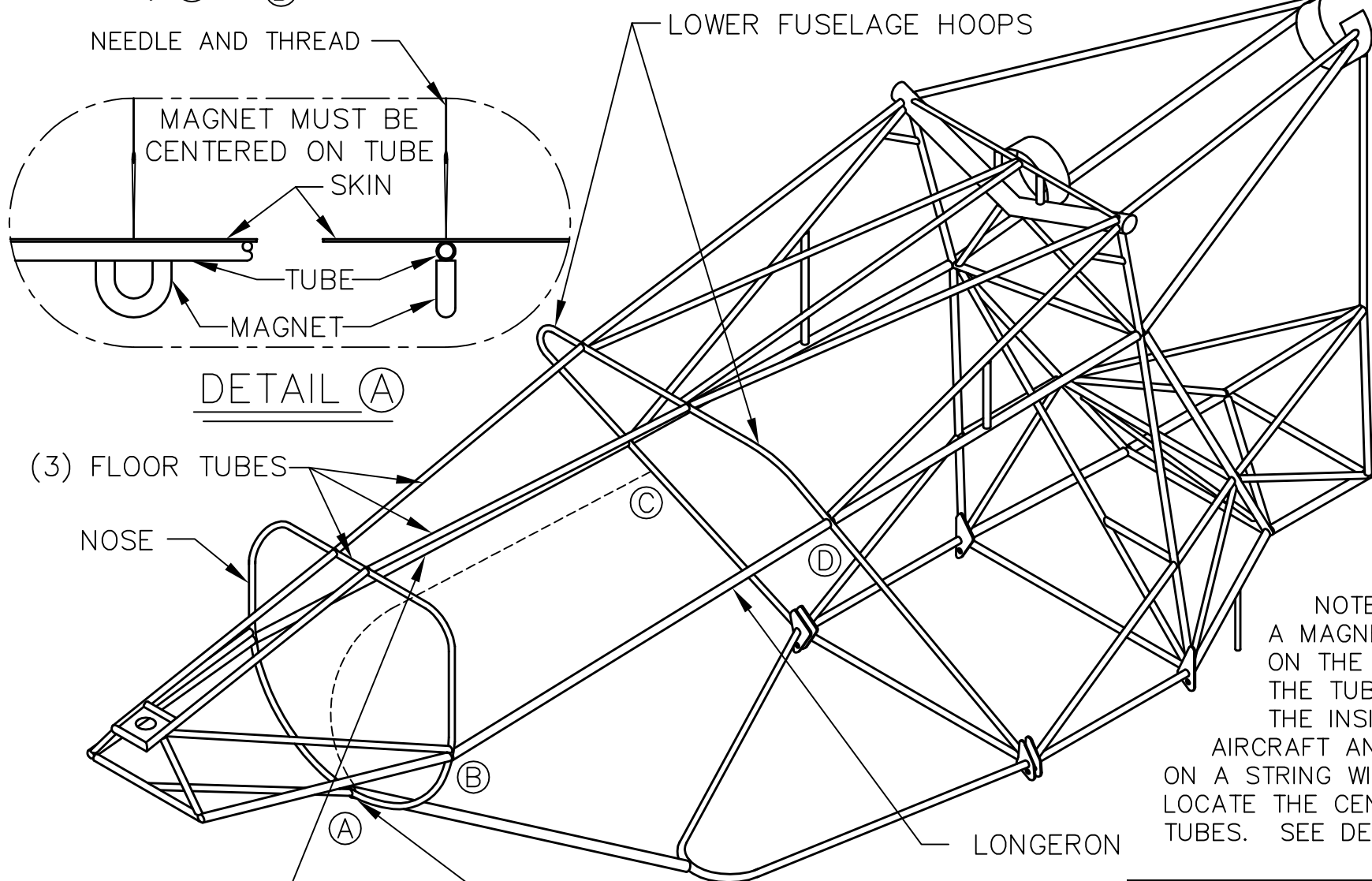

DETAIL A

LONGERON EDGE OF SKIN IS PLACED 4.000 INCHES ABOVE THIS TUBE (ALONG DASHED LINE).

DOWN TUBE POINT "A" OF SKIN SHOULD OVERLAP DOWN TUBE HERE.

NOTES:

- AFT BELLY SKIN SHOULD ALREADY BE FITTED. REMOVE AFT BELLY SKIN FROM FUSELAGE.
- CUT FORWARD BELLY SKIN OUT OF SHEET ALUMINUM 1-2" OVERSIZED USING THE PATTERN PROVIDED AND TRIM TO FIT.
- POSITION SKIN ON FUSELAGE SO THAT THE SKIN EDGE IS 4.000" ABOVE FUSELAGE LONGERON TUBE SHOWN.
- CLAMP SKIN TO FUSELAGE. TO HELP HOLD SKIN FLAT, CLAMP A BOARD TO SKIN AND FUSELAGE NEAR TUBES THAT ARE TO BE DRILLED.
- CHECK SKIN TO BE SURE IT IS TIGHT AGAINST FUSELAGE.
- CHECK SKIN TO SEE IF IT OVERLAPS THE DOWN TUBE.
- ALL RIVET HOLES *MUST* BE DRILLED THRU THE CENTERS OF FUSELAGE TUBES. DRILL ALL RIVET HOLES WITH #30 DRILL (.1285 DIA). CLECO SKIN TO FRAME AS IT IS BEING DRILLED.
- DRILL RIVET HOLES ON THE (3) "FLOOR TUBES" FIRST. DRILL ON 1.500 INCH CENTERS.
- DRILL LONGERON TUBES NEXT. DRILL ON 1.500 INCH CENTERS. BE SURE SKIN IS SQUARE AND TIGHT BEFORE DRILLING. DO NOT DRILL LOWER FUSELAGE HOOPS AT THIS POINT.
- DRILL "NOSE" ON 2.000 INCH CENTERS. DO NOT DRILL "NOSE" PAST THE "LONGERONS". FOR BEST RESULTS TAP SKIN ALONG THE "NOSE" WITH A RUBBER Mallet. THE LINE THAT FORMS IS NEAR THE CENTERLINE. DRILL AND CLECO PROGRESSIVELY.
- REMOVE FORWARD BELLY SKIN. CLECO AFT BELLY SKIN TO ALL DRILLED TUBES EXCEPT THE "LOWER FUSELAGE HOOPS". REASSEMBLE FORWARD BELLY SKIN TO FUSELAGE.
- DRILL MOUNTING HOLES THRU FORWARD BELLY SKIN FOR "LOWER FUSELAGE HOOPS". THESE HOLES MUST BE IN THE SAME POSITION AS HOLES THRU THE AFT BELLY SKIN. FOR BEST RESULTS, TAP THE SKINS WITH A RUBBER Mallet ALONG THE "LOWER FUSELAGE HOOPS". INDENTATIONS WILL FORM WHERE EACH HOLE IS POSITIONED.
- DO NOT DRILL RIVET HOLES ON ANY OTHER TUBES. RIVETING TO OTHER TUBES MAY CAUSE DENTS IN THE SKIN.
- PERMANENTLY INSTALL SKINS WITH SD42BS RIVETS AFTER INTERIOR OF FUSELAGE IS BUILT UP. FORWARD SKIN SHOULD OVERLAP AFT SKIN.
- AFTER BOTH SKINS ARE INSTALLED, ROLL THE SHORTER DOOR SIDE EDGE (NOT THE 4.000 INCH EDGE) AROUND THE LONGERON TUBE. FOR BEST RESULTS USE A BREAK OR RUBBER Mallet.

NOTES:
A MAGNET PLACED ON THE CENTER OF THE TUBE FROM THE INSIDE OF THE AIRCRAFT AND A NEEDLE ON A STRING WILL HELP TO LOCATE THE CENTER OF THE TUBES. SEE DETAIL A

TITAN AIRCRAFT SUPPLY
1419 STATE ROUTE 45 SOUTH
AUSTINBURG, OHIO 44010

DETAIL NAME FORWARD BELLY SKIN INSTALLATION

SCALE N/A PART NO.

ASSEMBLY NAME TWO PLACE TORNADO

PART NO. DRAWING NO.

DRAWING NO. **B 92-INS-0255-B**

DRAWN J. PRESTON	DATE 8/31/92
CHECKED B. PASSAFIUME	DATE 11/21/96
APPROVED J. WILLIAMS	DATE 11/26/96