

REVISIONS				
E.C. NO.	REV.	DESCRIPTION	BY	DATE
	A	DRAWING RELEASED	BH	2/10

NOTES:

- REMOVE AN380-3-3 COTTER PINS FROM AN6-31 BOLTS THAT RUN THROUGH THE FUSELAGE MOUNT. REMOVE THE AN310-6 CASTLE NUTS AND AN960-616 WASHER FROM EACH BOLT.
- DEPENDING ON HOW YOUR ENGINE WIRES, LINES, ETC ARE ROUTED, YOU SHOULD NOW BE ABLE TO LIFT THE ENGINE FAR ENOUGH OFF THE AIRFRAME TO REMOVE THE FUSELAGE MOUNT PLATES AND MODIFIED EACH TO THE DRAWING GIVEN BELOW.
- REMOVE THE AN6-31 BOLTS FROM THE AIRFRAME AND REPLACE WITH THE SUPPLIED AN6-33 BOLTS.
- ASSEMBLE THE ENGINE MOUNT BRACES ON THE AIRCRAFT AS SHOWN.
- ASSEMBLE THE MODIFIED FUSELAGE MOUNT PLATES ON TOP OF THE BRACES AS SHOWN.
- LOWER ENGINE BACK DOWN ON THE AIRFRAME AND BOLT EVERYTHING IN TO PLACE. MAKE SURE TO USE NEW COTTER PINS ON EACH BOLT. REATTACH ANY WIRES, LINES, ETC, THAT WERE DISCONNECTED.

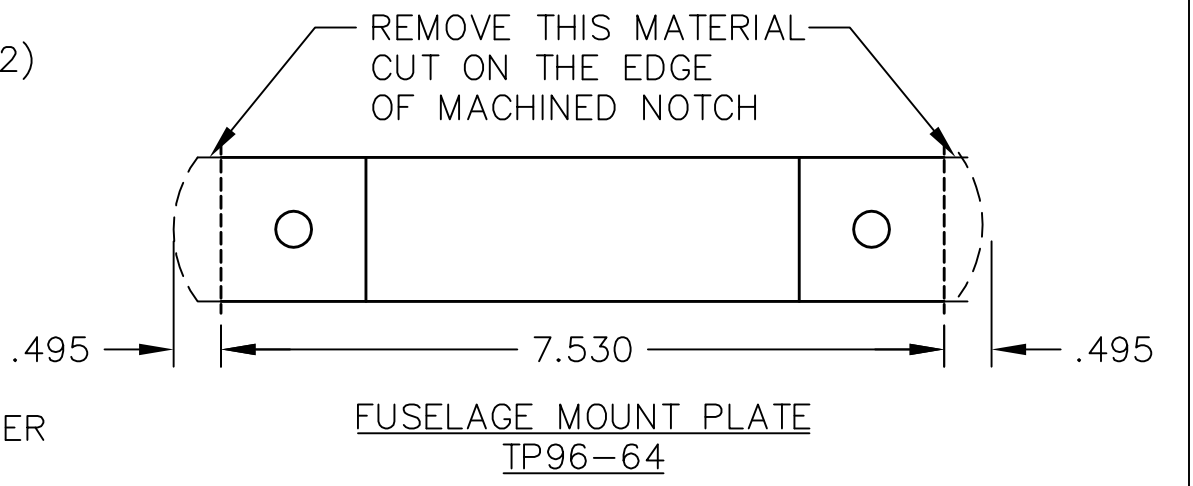

THIS DOCUMENT PROPRIETARY TO TITAN AIRCRAFT, AND IS NOT TO BE USED, CIRCULATED, REPRODUCED, COPIED, OR DISCLOSED IN ANY MANNER WITHOUT PRIOR WRITTEN PERMISSION OF AN AUTHORIZED OFFICIAL OF TITAN AIRCRAFT.

TITAN AIRCRAFT SUPPLY
 1419 STATE ROUTE 45 SOUTH
 AUSTINBURG, OHIO 44010

DRAWN B. HARE		DATE 2/8/10	DETAIL NAME ROTAX 912 ENGINE MOUNT BRACE INSTALLATION	
CHECKED R. INGLE		DATE 4/5/10	SCALE N/A	PART NO.
APPROVED J. WILLIAMS		DATE 4/5/10	ASSEMBLY NAME	
			PART NO.	DRAWING NO.
			DRAWING NO. B 10-INS-1469-A	