

THIS DOCUMENT PROPRIETARY TO TITAN AIRCRAFT, AND IS NOT TO BE USED, CIRCULATED, REPRODUCED, COPIED, OR DISCLOSED IN ANY MANNER WITHOUT PRIOR WRITTEN PERMISSION OF AN AUTHORIZED OFFICIAL OF TITAN AIRCRAFT.

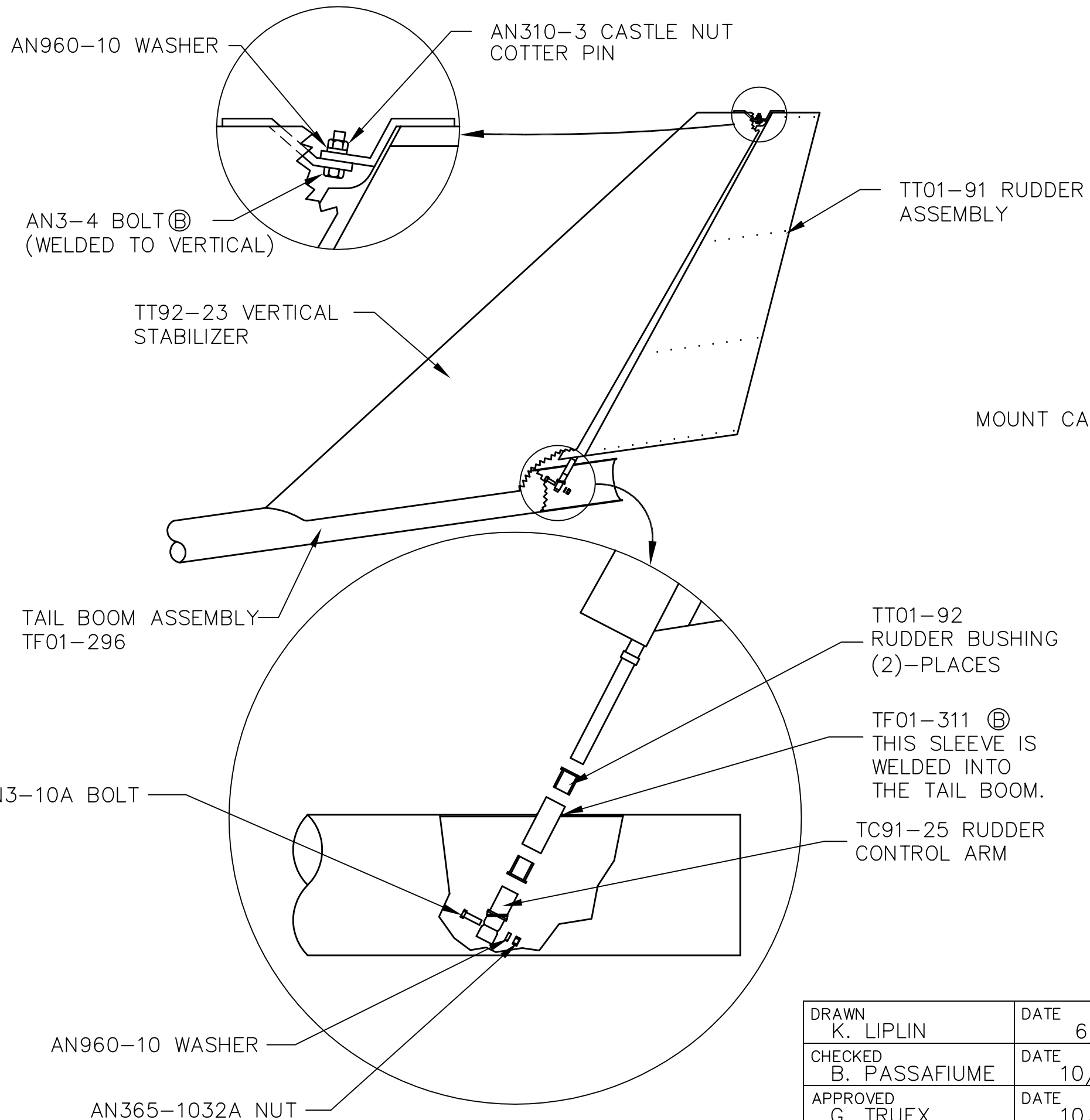

REVISIONS				
E.C. NO.	REV.	DESCRIPTION	BY	DATE
	A	DRAWING RELEASED	KL	6/01
2019	B	ADDED PART NO. TF01-311	KL	10/01

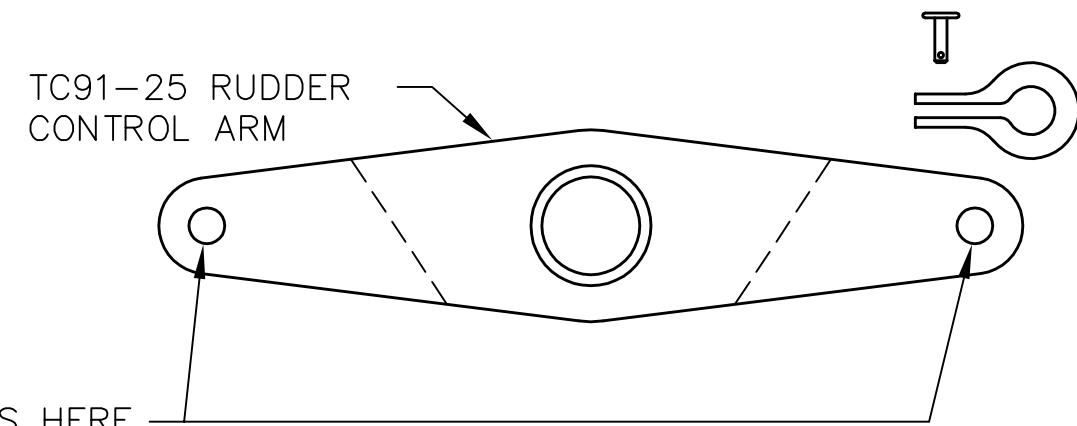

NOTES:

- ROUTE CABLES FROM RUDDER PEDALS THRU TAIL BOOM. FOR CABLE ROUTING SEE THE FOLLOWING DRAWINGS: B92-INS-0190 FOR SINGLE PLACE AIRCRAFT. B92-INS-0236 FOR TWO PLACE AIRCRAFT.
- ATTACH CABLES TO RUDDER CONTROL ARM USING CLEVIS AND PIN METHOD.
- INSERT RUDDER CONTROL ARM INTO TAIL BOOM AND HOLD IN POSITION.
- SLIDE RUDDER SHAFT THRU ONE RUDDER BUSHING, THRU THE WELDED ALUMINUM SLEEVE, THRU TO THE OTHER RUDDER BUSHING, AND THRU TO THE RUDDER CONTROL ARM.
- BOLT RUDDER CONTROL ARM TO THE RUDDER USING THE PREDRILLED HOLES. BOLT WITH AN3-10A BOLT, AN365-1032A NUT, AND AN960-10 WASHER.

TITAN AIRCRAFT SUPPLY
 1419 STATE ROUTE 45 SOUTH
 AUSTINBURG, OHIO 44010

DETAIL NAME		RUDDER INSTALLATION	
SCALE	N/A	PART NO.	
ASSEMBLY NAME		TORNADO S	
PART NO.		DRAWING NO.	
DRAWING NO.		B 01-INS-1241-B	

DRAWN	K. LIPLIN	DATE	6/12/01
CHECKED	B. PASSAFIUME	DATE	10/22/01
APPROVED	G. TRUEX	DATE	10/22/01