

REVISIONS

E.C. NO.	REV.	DESCRIPTION	BY	DATE
	A	DRAWING RELEASED	SH	3/09

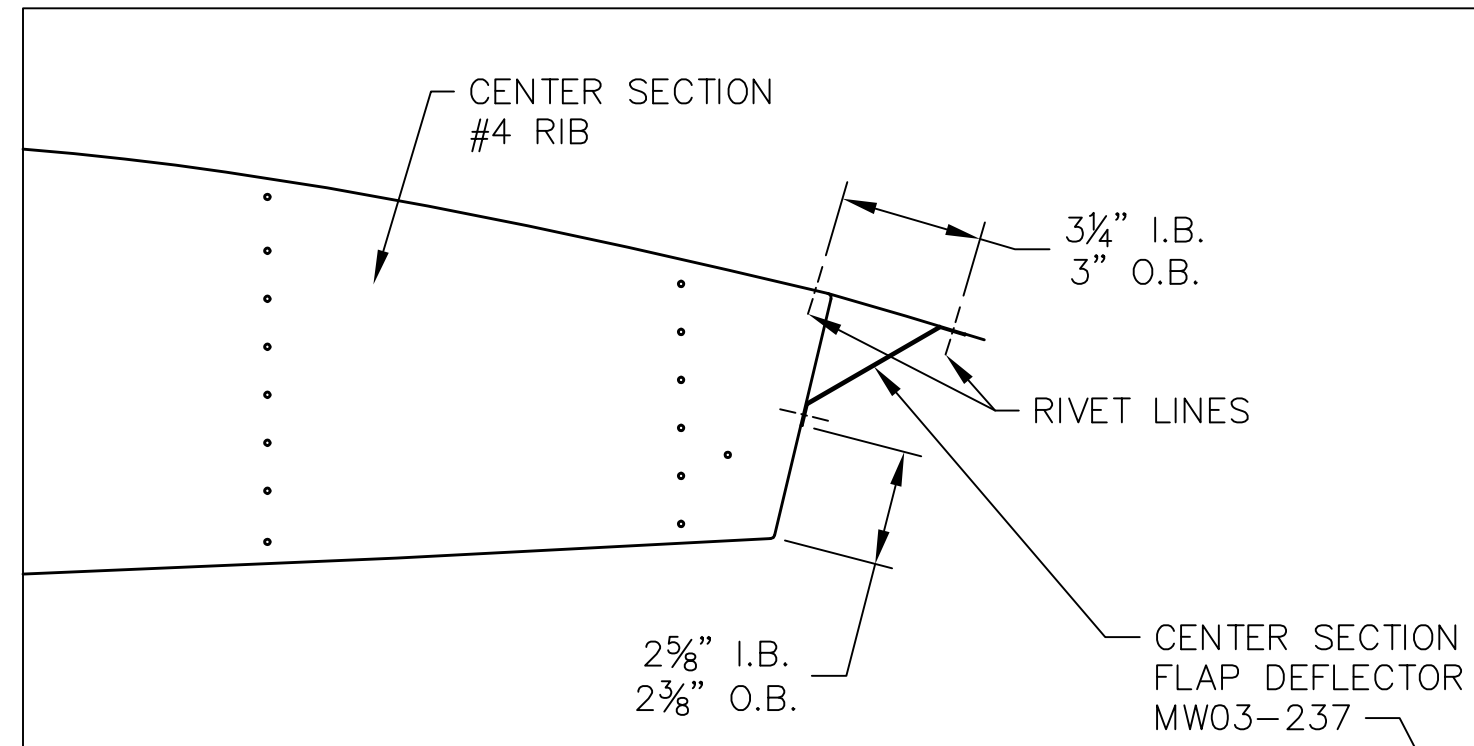

NOTES:

- SEE DRAWING T51-09-INS-1849 FOR CENTER SECTION AND WING MATTING INSTRUCTIONS.
- MATCH DRILL THE $\phi 5/16$ " HOLE FROM THE AFT SPAR WING FITTING (MW02-14) INTO THE CENTER SECTION AFT SPAR. SECURE THE FITTING WITH AN5-6A BOLT, AN960-516 WASHER AND AN365-524 LOCKNUT.
- USE A $\phi 3/8$ " DRILL TO REMOVE MATERIAL FOR RIVET HEADS ON THE FLAP DEFLECTORS AS SHOWN AT 11 5/8" AND 12 5/8".
- USE MS204263-3 SOLID RIVETS ON THE TOP FLANGE OF THE DEFLECTORS & SD42BS RIVETS ON THE BOTTOM FLANGE.
- REFER TO DRAWING T51-05-INS-1292 FOR WING DEFLECTOR INSTALLATION INSTRUCTIONS FOR OUTBOARD WING PANEL.

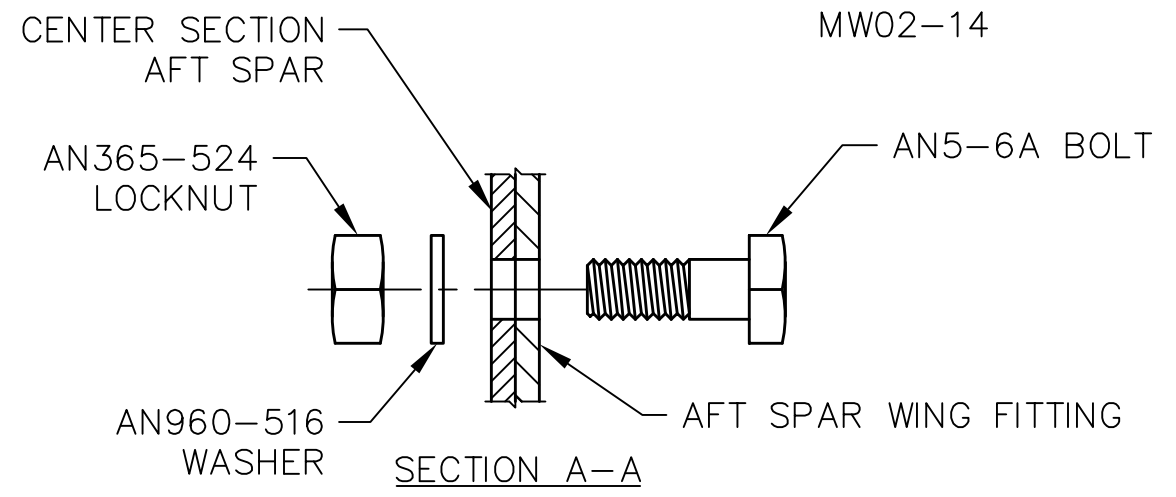
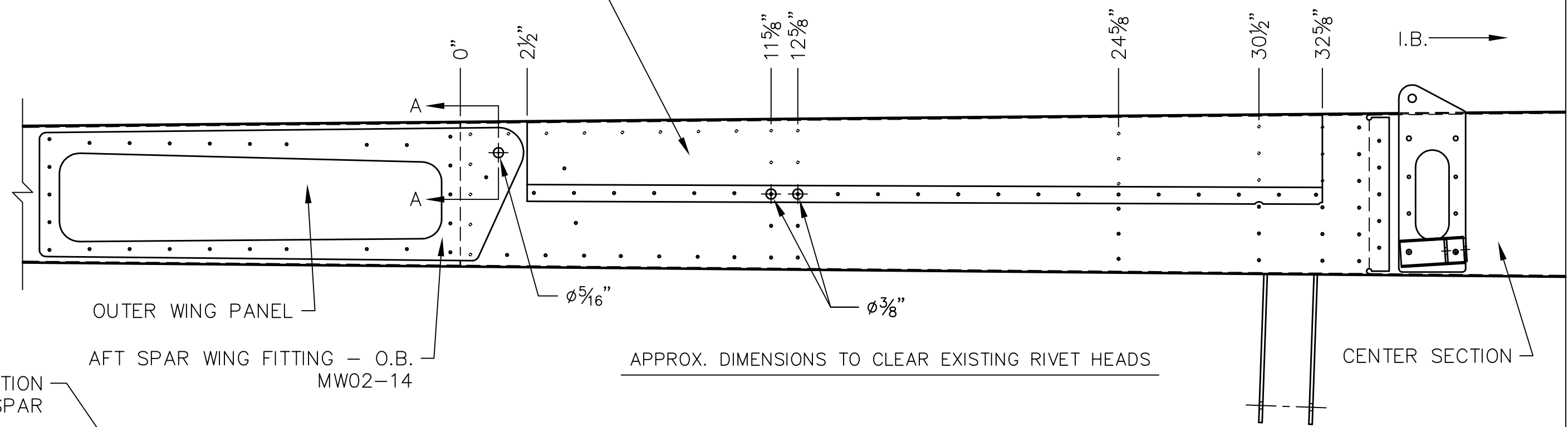

LH SIDE SHOWN
(RH OPPOSITE)

TITAN AIRCRAFT SUPPLY
 1419 STATE ROUTE 45 SOUTH
 AUSTINBURG, OHIO 44010

DETAIL NAME CENTER SECTION FLAP DEFLECTOR INSTALLATION	
SCALE 1/4"=1"	PART NO.
ASSEMBLY NAME FOR A/C SERIAL # 151 & EARLIER	
PART NO.	DRAWING NO. CS22
DRAWING NO. B T51-09-INS-1813-A	

DRAWN S. HENDERSON	DATE 3/19/09
CHECKED R. INGLE	DATE 6/1/10
APPROVED K. BROOKS	DATE 6/2/10

THIS DOCUMENT PROPRIETARY TO TITAN AIRCRAFT, AND IS NOT TO BE USED, CIRCULATED, REPRODUCED, COPIED, OR DISCLOSED IN ANY MANNER WITHOUT PRIOR WRITTEN PERMISSION OF AN AUTHORIZED OFFICIAL OF TITAN AIRCRAFT.