

| REVISIONS | | | | |
|-----------|------|------------------|----|------|
| E.C. NO. | REV. | DESCRIPTION | BY | DATE |
| | A | DRAWING RELEASED | SH | 8/05 |
| | | | | |
| | | | | |

NOTE:

- POSITION THE EXHAUST STACK SO THAT THEY WILL MATCH WITH THE EXIT TUBES. (LH SIDE OF PLANE ONLY)
- MARK OFF WHERE THE EXHAUST STACK SHOULD BE MOUNTED.
- MAKE SURE THAT AT LEAST 1/4" OF THE SKIN IS OVERLAPPING THE FLANGE OF THE EXHAUST STACK, SO THAT THE STACK CAN BE FASTENED TO THE SKIN. (BE SURE TO DIMPLE SKINS BEFORE ATTACHING EXHAUST STACK.)
- DRILL (2) 3/16" HOLES IN THE TOP & THE BOTTOM OF EXHAUST STACK 3" IN FROM THE ENDS FOR MOUNTING TO SKIN.
- USE EXHAUST STACK SPACERS (MP07-131) BETWEEN THE EXHAUST STACK FLANGE & THE SKIN.

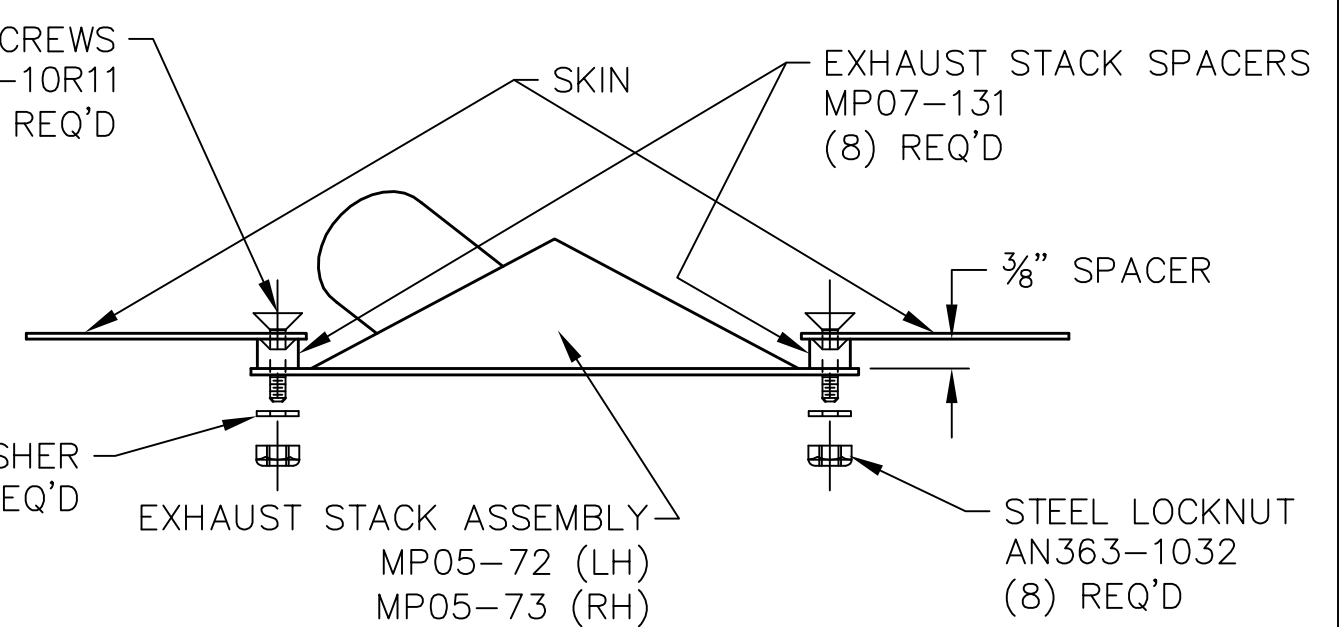
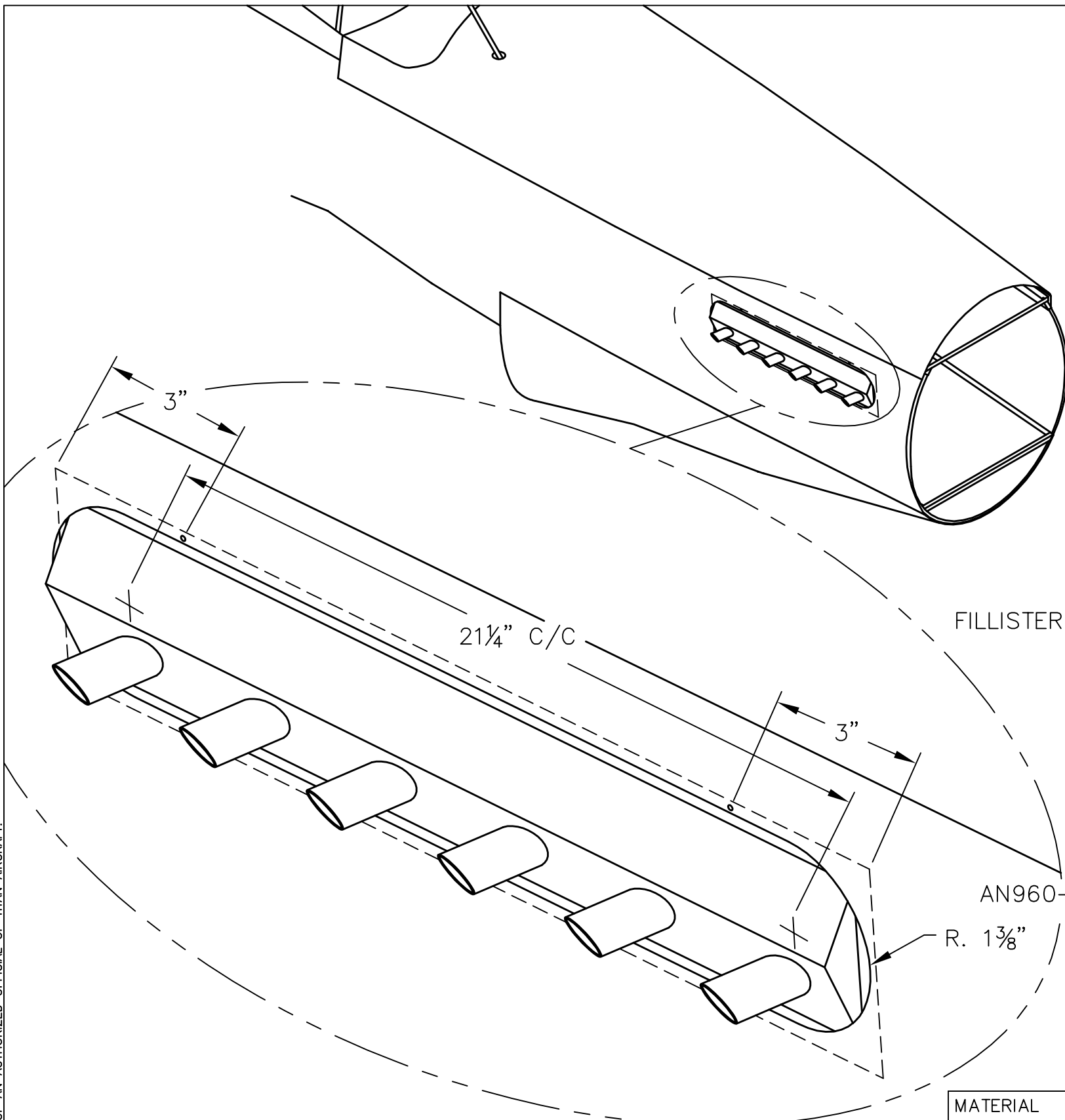

THIS DOCUMENT PROPRIETARY TO TITAN AIRCRAFT, AND IS NOT TO BE USED, CIRCULATED, REPRODUCED, COPIED, OR DISCLOSED IN ANY MANNER WITHOUT PRIOR WRITTEN PERMISSION OF AN AUTHORIZED OFFICIAL OF TITAN AIRCRAFT.

UNLESS OTHERWISE SPECIFIED:
 - ALL DIMENSIONS ARE IN INCHES.
 - APPLY STANDARD TOLERANCES:
 0.00 = ±.030
 0.000 = ±.010
 ANGULAR ±1°
 - BREAK ALL SHARP CORNERS

| | | | |
|----------|--------------|----------|---------|
| MATERIAL | | AS NOTED | |
| DRAWN | S. HENDERSON | DATE | 8/8/05 |
| CHECKED | RI | DATE | 4/11/07 |
| APPROVED | JW | DATE | 4/27/07 |



TITAN AIRCRAFT

TITAN AIRCRAFT SUPPLY
 1419 STATE ROUTE 45 SOUTH
 AUSTINBURG, OHIO 44010

| | | | |
|---------------|-----|---------------------------------------|--|
| DETAIL NAME | | EXHAUST STACK INSTRUCTIONAL (CAM 125) | |
| SCALE | N/A | PART NO. | |
| ASSEMBLY NAME | | | |
| PART NO. | | DRAWING NO. | |
| DRAWING NO. | | B T51-05-INS-1209-A | |