

REVISIONS				
E.C. NO.	REV.	DESCRIPTION	BY	DATE
	A	DRAWING RELEASED	BH	11/03
0317	B	NOTES ADDED	SH	8/06
0857	C	BOLTS FLIPPED OVER/WASHERS ADDED	SH	1/09

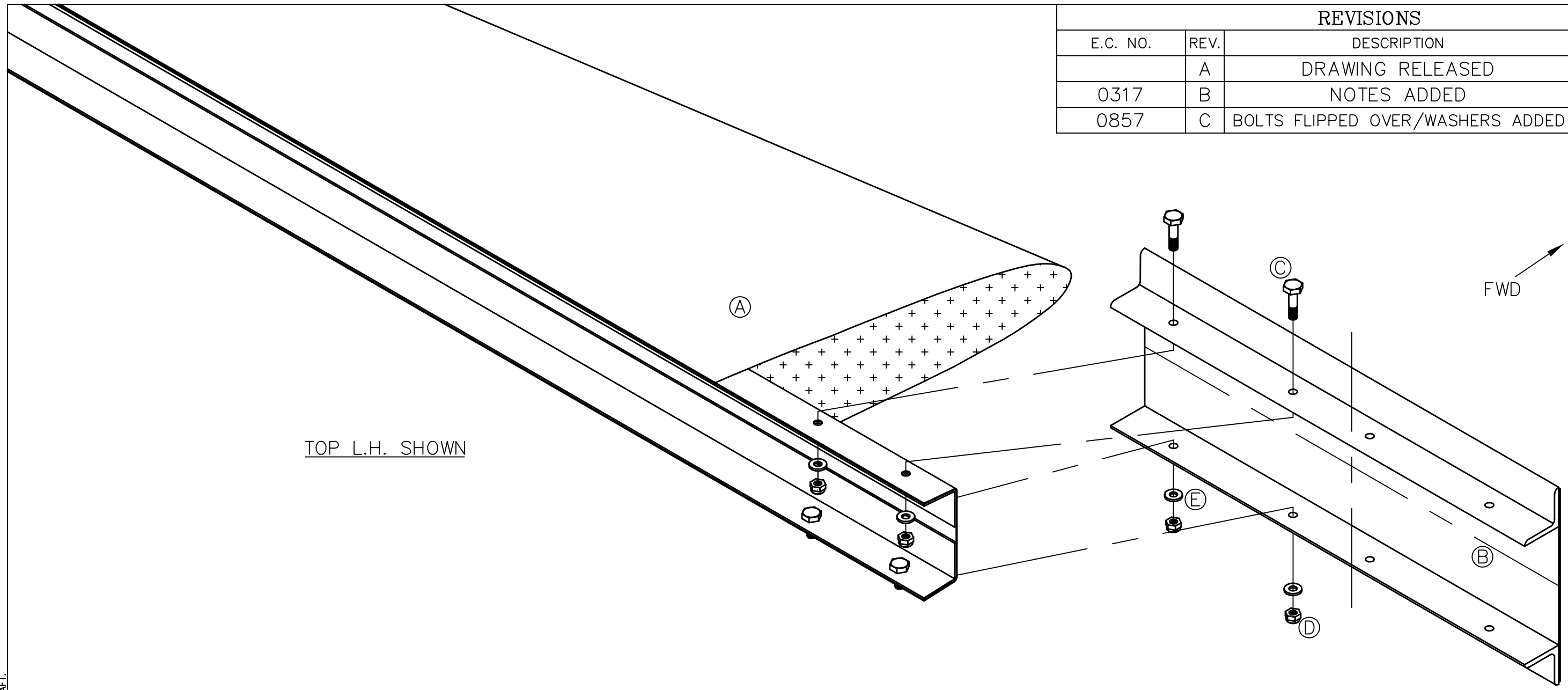

TOP L.H. SHOWN

NOTES:
 - SEE PRINTS T51-03-INS-0844 AND T51-09-INS-1808.
 - VERTICAL STABILIZER SHOULD BE MOUNTED PRIOR TO HORIZONTAL INSTALLATION.
 - IT IS RECOMMENDED TO ASSEMBLE THE FWD SPARS AND CARRYTHRU ON A FLAT TABLE RATHER THAN ON THE FUSELAGE FRAME TO MAKE SURE THINGS STAY STRAIGHT AND CENTERED.

TITAN AIRCRAFT SUPPLY
 1419 STATE ROUTE 45 SOUTH
 AUSTINBURG, OHIO 44010

SYM.	QTY.	DESCRIPTION
A	2	HORIZONTAL STABLIZER - MT06-199
B	1	FWD SPAR CARRYTHRU - MT03-28
C	8	AN3-5A BOLT
D	8	AN365-1032 LOCK NUT
E	8	AN960-10 WASHERS

DRAWN C. EMERY	DATE 11/18/03
CHECKED R. INGLE	DATE 1/25/10
APPROVED K. BROOKS	DATE 1/26/10

DETAIL NAME HORIZONTAL STABILIZER INSTALLATION - FWD	
SCALE N/A	PART NO.
ASSEMBLY NAME	
PART NO.	DRAWING NO. F36
DRAWING NO. B T51-03-INS-0937-C	

THIS DOCUMENT PROPRIETARY TO TITAN AIRCRAFT, AND IS NOT TO BE USED, CIRCULATED, REPRODUCED, COPIED, OR DISCLOSED IN ANY MANNER WITHOUT PRIOR WRITTEN PERMISSION OF AN AUTHORIZED OFFICIAL OF TITAN AIRCRAFT.