

NOTES:

- INSTALL "O" RING (MG02-122) ON THE PISTON (MG01-27).
- ASSEMBLE THE PISTON, UPPER OLEO SLEEVE AND PISTON PIN TO THE OLEO STRUT.
- SLIDE THE OLEO SPACER (MG02-101) ONTO THE OLEO STRUT.
- SLIDE THE ASSEMBLED OLEO STRUT INTO THE UPPER MAIN GEAR WELDMENT.
- INSTALL "O" RING (MG02-124) ONTO THE LOWER OLEO SLEEVE AND "O" RING (MG02-123) INTO THE OLEO SLEEVE.
- SLIDE THE ASSEMBLED LOWER OLEO SLEEVE OVER THE OLEO STRUT AND INTO THE UPPER MAIN GEAR WELDMENT.
- INSTALL THE 2" SNAP RING (MG02-110)
- ** CAUTION **** THIS SNAP RING HOLDS THE PRESSURIZED OLEO TOGETHER, THE SNAP RING MUST BE SEATED CORRECTLY. IF NOT, THE OLEO MAY BLAST APART WHEN THE AIRCRAFT WEIGHT IS OFF THE LANDING GEAR (AFTER TAKEOFF).
- TO FILL THE STRUTS, MAKE SURE THE AIRCRAFT IS SUPPORTED BY THE LANDING GEAR ON ALL THREE POINTS, THE MAINS WILL BE FULLY COLLAPSED AT THIS TIME. REMOVE THE OLEO VALVE (MG02-115). FILL A SQUEEZE BOTTLE WITH MIL-5606 HYDRAULIC FLUID (OR EQUIVALENT) AND ATTACH A HOSE ON THE END. INSERT THE HOSE WHERE THE OLEO VALVE WAS AND SLOWLY FILL UNTIL THE FLUID STARTS TO DRIBBLE OUT. USE TEFLON TAPE ON THE OLEO VALVE THREADS AND TORQUE UNTIL TIGHT.
- TO PRESSURIZE THE STRUTS, USE JACKS TO LIFT THE MAIN GEAR OFF THE GROUND. USE AN AIR HOSE TO FILL THE STRUT WITH NITROGEN (OR COMPRESSED AIR) TO 185 PSI FOR SMALL (2") GEAR AND 115 PSI FOR LARGE (3") GEAR. LET THE AIRCRAFT OFF THE JACKS AND LEAKDOWN AS NEEDED TO LEVEL THE MAINS.

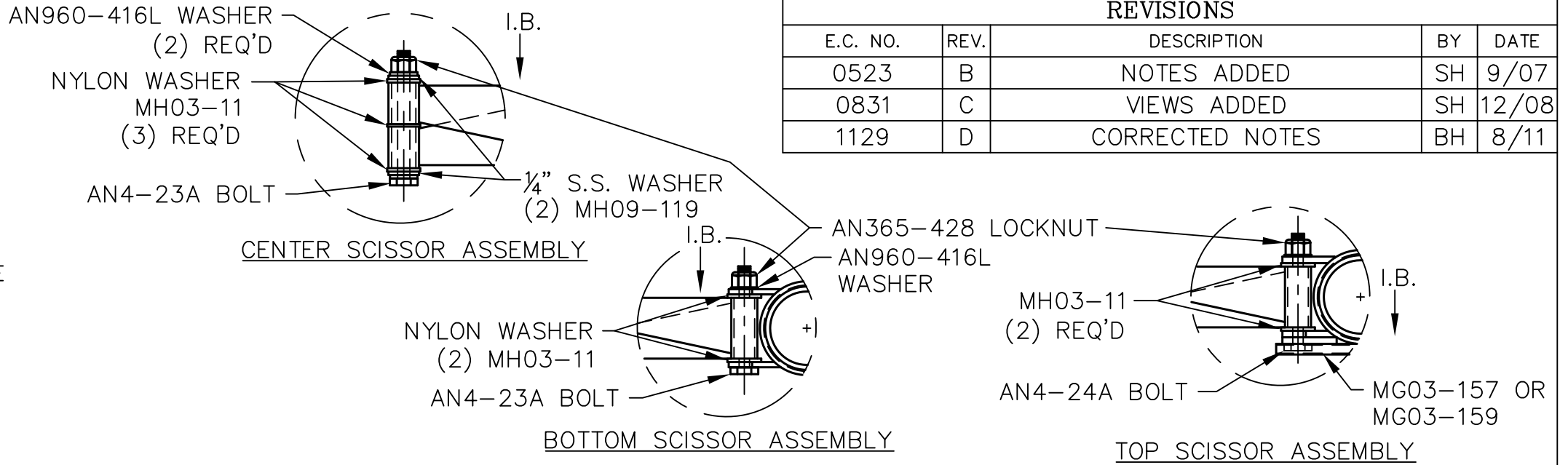

REVISIONS				
E.C. NO.	REV.	DESCRIPTION	BY	DATE
0523	B	NOTES ADDED	SH	9/07
0831	C	VIEWS ADDED	SH	12/08
1129	D	CORRECTED NOTES	BH	8/11

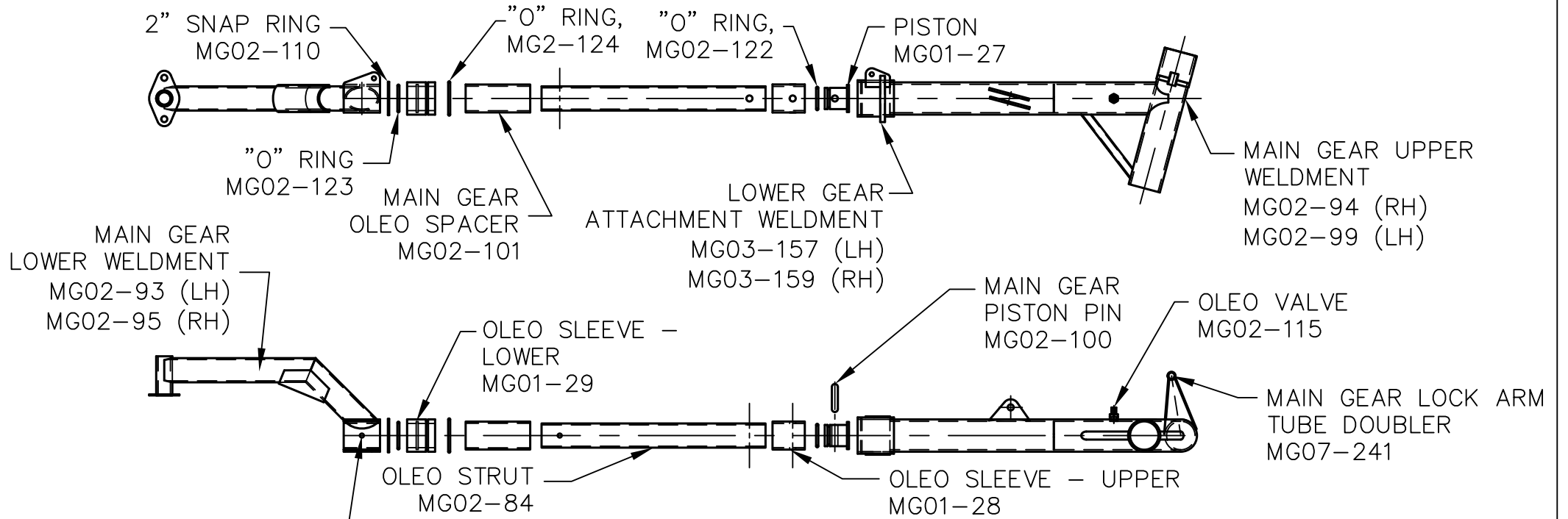

LH GEAR LEG SHOWN
(RH OPPOSITE)

AN4-21A BOLT
AN960-416 WASHER
AN365-428 LOCKNUT

TITAN AIRCRAFT SUPPLY
1419 STATE ROUTE 45 SOUTH
AUSTINBURG, OHIO 44010

DETAIL NAME		OLEO EXPLODED VIEW	
SCALE 1/8"=1"	PART NO.		
ASSEMBLY NAME		DRAWING NO. LG1	
PART NO.		DRAWING NO. <i>B T51-03-INS-0589-D</i>	

DRAWN K. LIPLIN	DATE 1/22/03
CHECKED J.W.	DATE 10/15/18
APPROVED	DATE

THIS DOCUMENT PROPRIETARY TO TITAN AIRCRAFT, AND IS NOT TO BE USED, CIRCULATED, REPRODUCED, COPIED, OR DISCLOSED IN ANY MANNER WITHOUT PRIOR WRITTEN PERMISSION OF AN AUTHORIZED OFFICIAL OF TITAN AIRCRAFT.