

NOTE FOR HINGE DOUBLER INSTALLATION - 10 PLACES:
 - USE SD42BS RIVETS WHERE RIB INTERSECTS DOUBLER
 - USE AD42ABS IN OTHER LOCATIONS
 - SEE BLOW UP PICTURES IN CIRCLES FOR DETAILS.
 - 5 RIVETS, EVENLY SPACED, PER DOUBLER
 - DO NOT RIVET ON SURFACES THAT WILL CONTACT WING SKINS AT THIS TIME.
 - BOND ALL HINGE DOUBLERS TO THE INSIDE OF THE AFT SPAR.

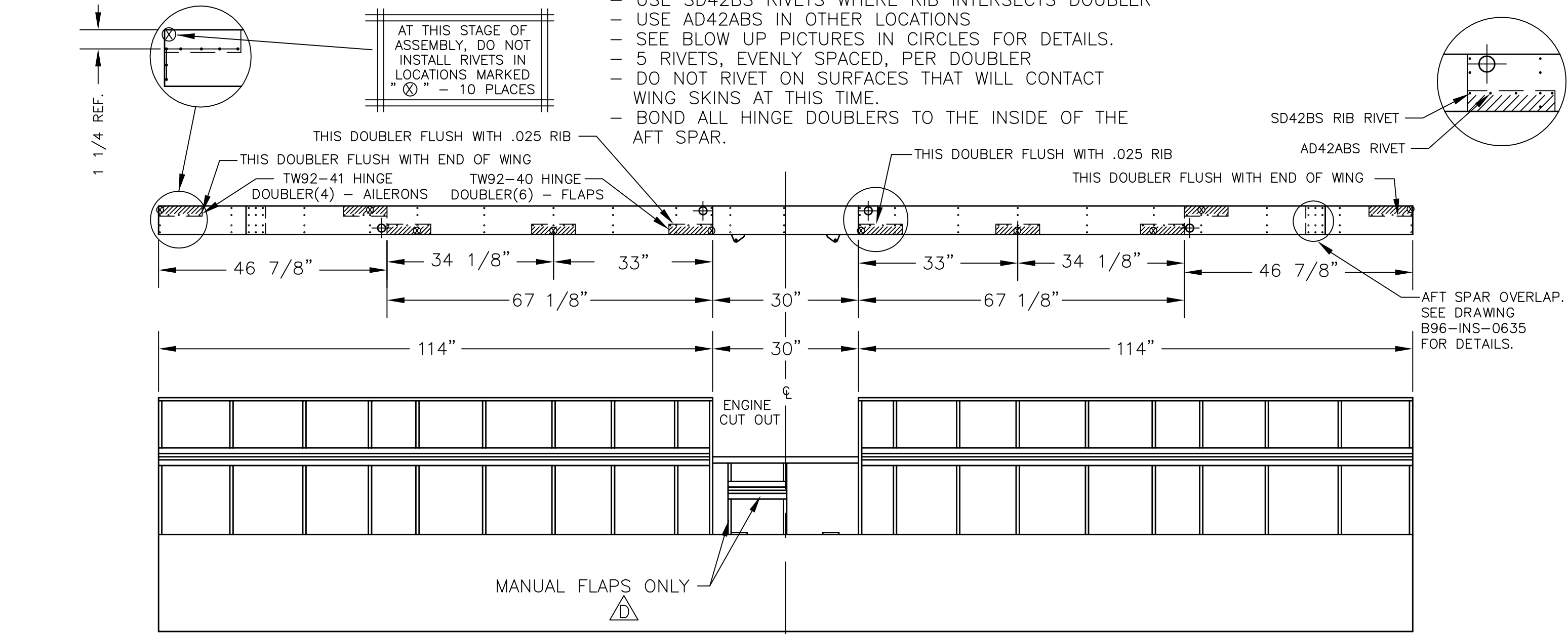

SD42BS RIB RIVET
 AD42ABS RIVET

AFT SPAR OVERLAP.
 SEE DRAWING
 B96-INS-0635
 FOR DETAILS.

MANUAL FLAPS ONLY
 ⚠

DO NOT RIVET ON THIS SURFACE AT THIS TIME

HINGE DOUBLER RIVET LINE. DRILL 1 1/4\"

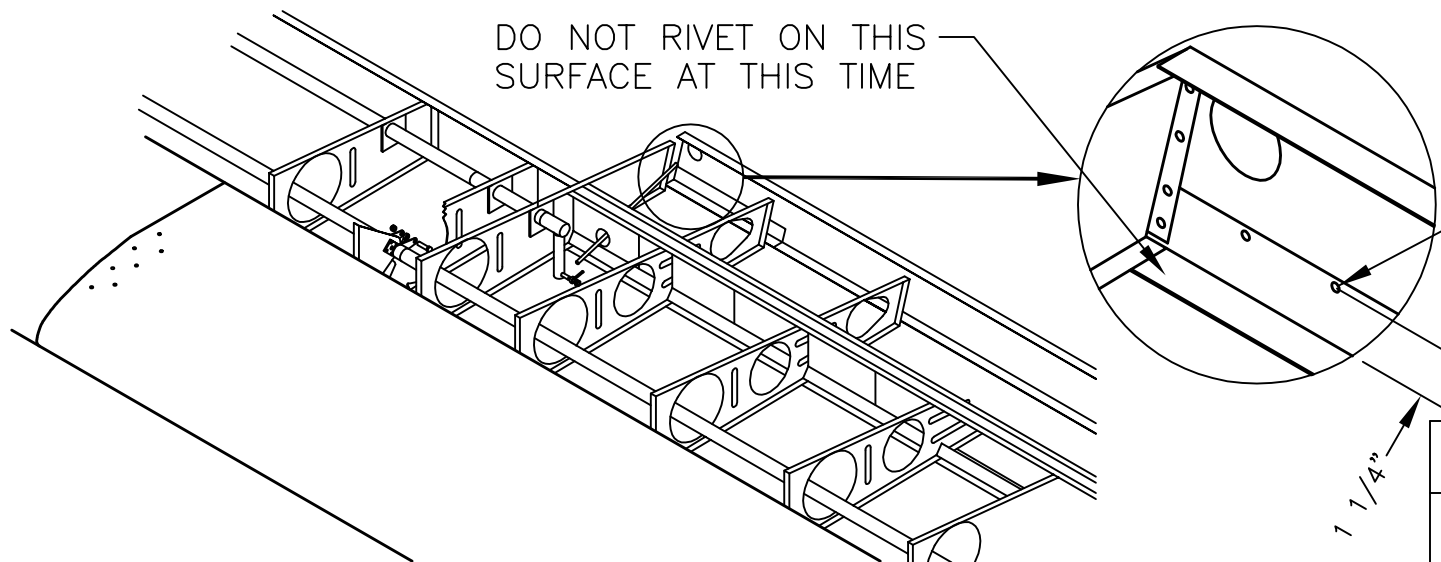

FOR FURTHER DETAILS ON WING CONSTRUCTION AND REAR SPAR INSTALLATION, SEE DRAWING B92-INS-0327 AND B95-INS-0635.

		TITAN AIRCRAFT SUPPLY 1419 STATE ROUTE 45 SOUTH AUSTINBURG, OHIO 44010	
DETAIL NAME		HINGE DOUBLER INSTALLATION	
SCALE	N/A	PART NO.	
ASSEMBLY NAME		23 1/2 FOOT WING	
PART NO.		DRAWING NO.	
DRAWING NO.		B 96-INS-0749-D	

DRAWN	K. BOHRER	DATE	9/30/96
CHECKED	GAT	DATE	10/4/05
APPROVED	JW	DATE	10/5/05

THIS DOCUMENT PROPRIETARY TO TITAN AIRCRAFT, AND IS NOT TO BE USED, CIRCULATED, REPRODUCED, COPIED, OR DISCLOSED IN ANY MANNER WITHOUT PRIOR WRITTEN PERMISSION OF AN AUTHORIZED OFFICIAL OF TITAN AIRCRAFT.