

THIS DOCUMENT PROPRIETARY TO TITAN AIRCRAFT, AND IS NOT TO BE USED, CIRCULATED, REPRODUCED, COPIED, OR DISCLOSED IN ANY MANNER WITHOUT PRIOR WRITTEN PERMISSION OF AN AUTHORIZED OFFICIAL OF TITAN AIRCRAFT.

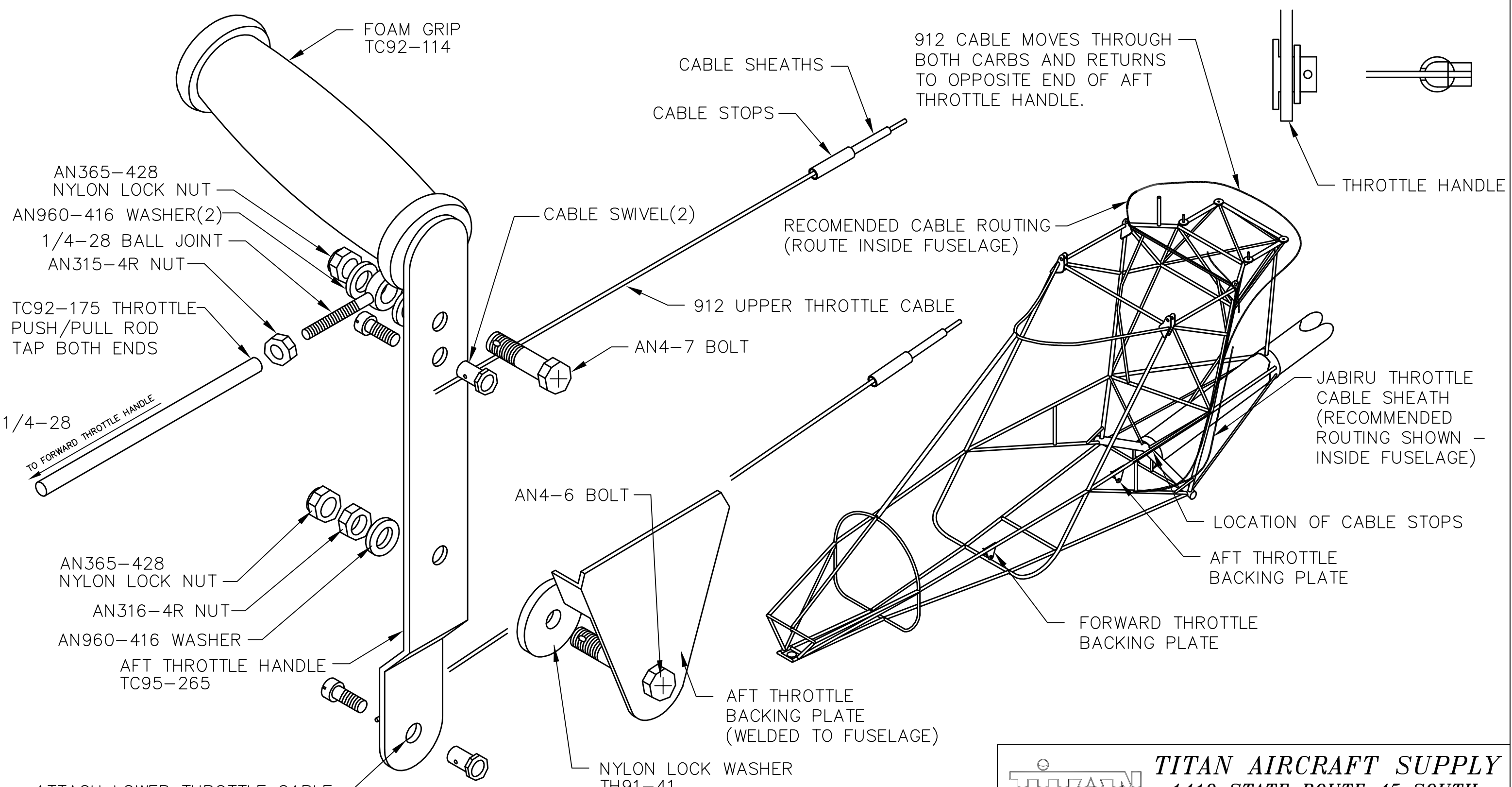

ATTACH LOWER THROTTLE CABLE
HERE FOR ROTAX 912 ENGINES.

- NOTES:
- THROTTLE CABLE IS SHEATHED FROM THE CABLE STOPS TO THE CARBURETOR.
 - TAP THROTTLE PUSH/PULL ROD 1/4-28 AT EACH END.

TITAN AIRCRAFT SUPPLY
1419 STATE ROUTE 45 SOUTH
AUSTINBURG, OHIO 44010

DRAWN J. PRESTON		DATE 10/22/92		SCALE N/A		PART NO.	
CHECKED R.I.		DATE 11/7/05		ASSEMBLY NAME 2 PLACE TORNADO W/ 912 ENGINE			
APPROVED J.W.		DATE 11/8/05		DRAWING NO. B		96-INS-0681-D	