

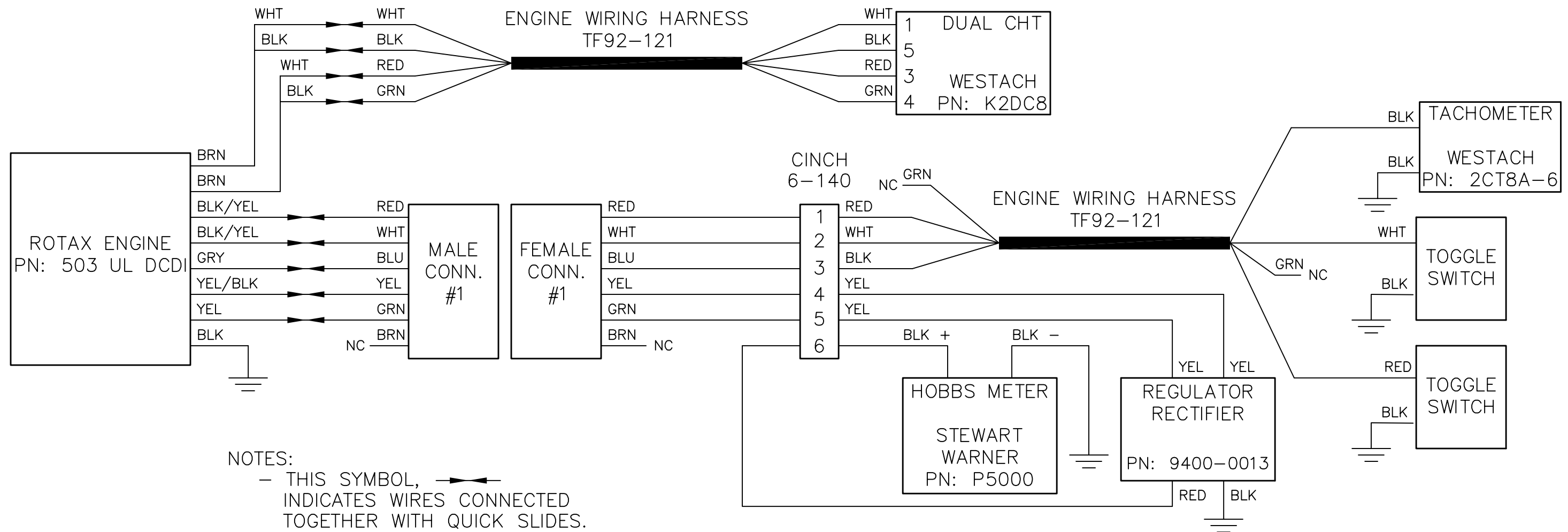

REVISIONS				
E.C. NO.	REV.	DESCRIPTION	BY	DATE
	B	REMOVED UNNECESSARY NOTES	K.B.	7/96
1121	C	NOW STATES W/O E. START	K.B.	6/97



- NOTES:
- THIS SYMBOL, , INDICATES WIRES CONNECTED TOGETHER WITH QUICK SLIDES.
 - TRIM ALL UNUSED WIRES TO TWO INCHES IN LENGTH, FOLD OVER AND WRAP IN ELECTRICAL TAPE.
 - REMOVE BROWN GROUND WIRE FROM ENGINE AND REPLACE WITH 8 GAUGE BLACK WIRE.
 - USE GREEN/YELLOW GROUND WIRE FOR EXPORT AIRCRAFT.
 - USE INSTRUMENTS LISTED OR EQUIVALENTS.
 - LABEL TERMINAL STRIP CONTACTS AND CORRESPONDING WIRES 1 THRU 6.

TITAN AIRCRAFT SUPPLY
 1419 STATE ROUTE 45 SOUTH
 AUSTINBURG, OHIO 44010

DETAIL NAME		503 WIRING DIAGRAM	
SCALE	PART NO.		
ASSEMBLY NAME		503 WITHOUT ELECTRIC START	
PART NO.	DRAWING NO.		
DRAWING NO.	B 92-DT-0248-C		

DRAWN J. PRESTON	DATE 8/20/92
CHECKED B. PASSAFIUME	DATE 6/24/97
APPROVED J. SUTCH	DATE 7/1/97