

REVISIONS

REV.	DESCRIPTION	BY	DATE
A	ADDED WIRE LENGTHS	JP	10/92
B	ADDED TWO NOTES	JP	10/92
C	REGULATOR WAS ROTAX 866-080	KB	7/96

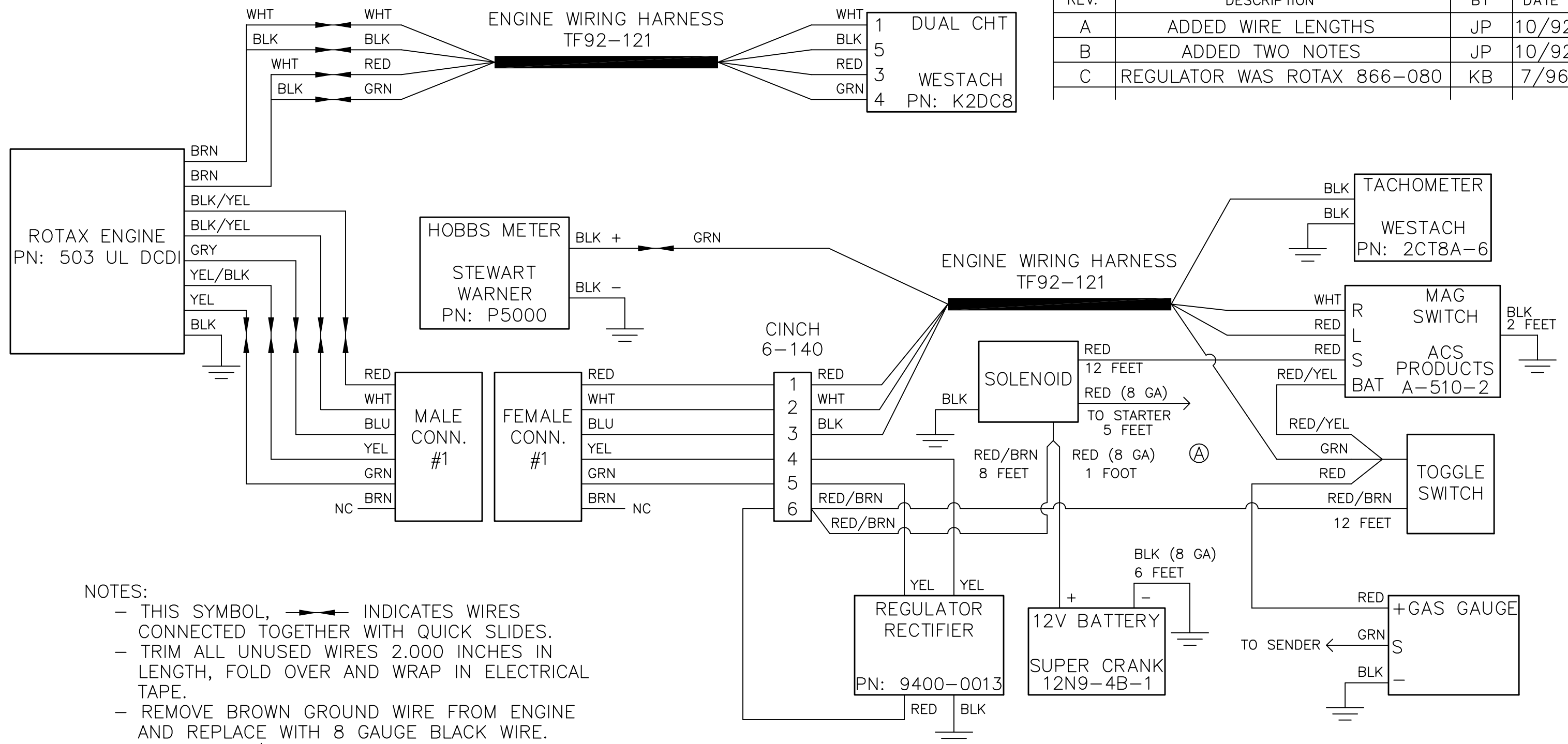

NOTES:

- THIS SYMBOL, \longleftrightarrow INDICATES WIRES CONNECTED TOGETHER WITH QUICK SLIDES.
- TRIM ALL UNUSED WIRES 2.000 INCHES IN LENGTH, FOLD OVER AND WRAP IN ELECTRICAL TAPE.
- REMOVE BROWN GROUND WIRE FROM ENGINE AND REPLACE WITH 8 GAUGE BLACK WIRE.
- USE GREEN/YELLOW GROUND WIRE FOR EXPORT AIRCRAFT.
- USE INSTRUMENTS LISTED OR EQUIVALENTS.
- LABEL TERMINAL STRIP CONTACTS AND CORRESPONDING WIRES 1 THRU 6.
- USE SPADE TERMINALS ON CINCH 6-140 TERMINAL STRIP.
- USE RING TERMINALS ON MAG SWITCH AND TOGGLE SWITCHES.

ⓑ

MATERIAL	
DRAWN J. PRESTON	DATE 8/19/92
CHECKED B. PASSAFIUME	DATE 7/16/96
APPROVED J. SUTCH	DATE 7/18/96

TITAN AIRCRAFT SUPPLY
 1419 STATE ROUTE 45 SOUTH
 AUSTINBURG, OHIO 44010

DETAIL NAME WIRING DIAGRAM	
SCALE	PART NO. N/A
ASSEMBLY NAME ELECTRIC START SYSTEM	
PART NO. N/A	DRAWING NO.
DRAWING NO. B 92-DT-0247-C	