

2" HOLE SAW
FOR ALUMINUM
SKIN

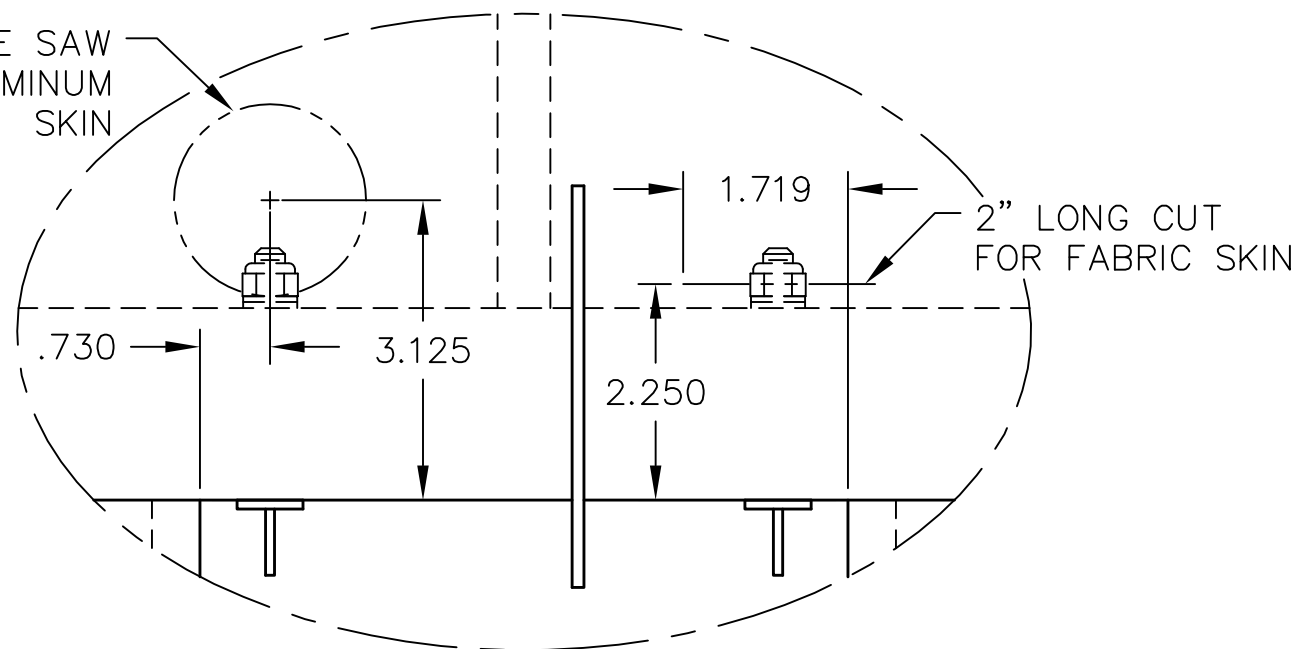
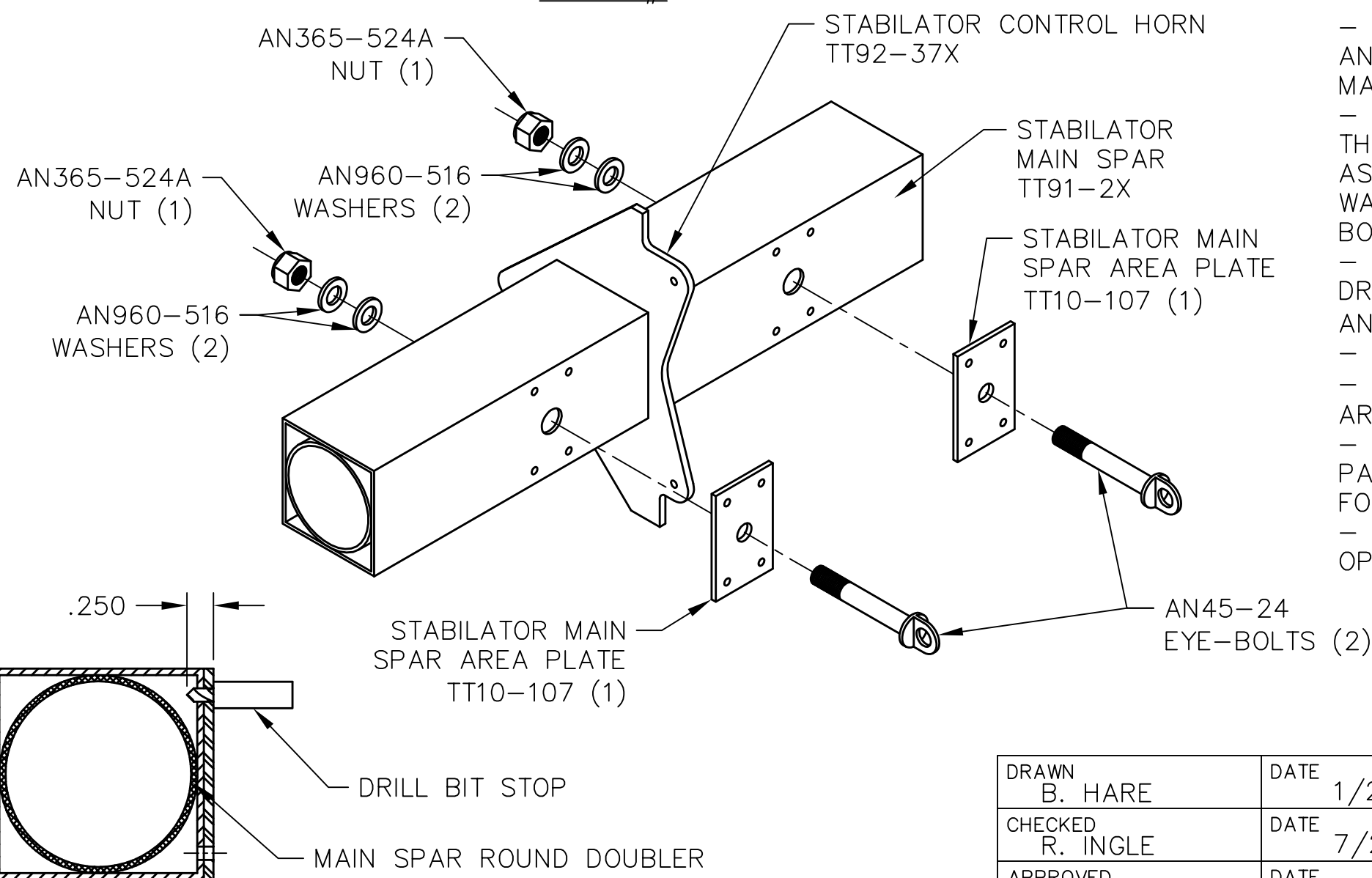

FIGURE #1



REVISIONS				
E.C. NO.	REV.	DESCRIPTION	BY	DATE
	A	DRAWING RELEASED	BH	1/10

NOTES:

- TO UNBOLT THE HORIZONTAL STABILATOR FROM THE AIRCRAFT, FIRST REMOVE THE CLEVIS PIN AND SLIDE THE PUSH/PULL TUBE OFF THE STABILATOR CONTROL HORN. NEXT, REMOVE THE AN365-1032A NUT, BALL JOINT, AND AN3-6A BOLT FROM THE ANTISERVO CONTROL HORN. FINALLY, REMOVE THE COTTER PINS, AN310-5 CASTLE NUTS, AND AN5-7 BOLTS ATTACHING THE STABILIZER TO THE STABILIZER MOUNT. THE WHOLE ASSEMBLY WILL THEN BE ABLE TO SLIDE OFF.
- PLACE THE STABILATOR UPSIDE DOWN ON A FLAT SURFACE.
- CUT THE LOWER SKIN USING THE DIMENSIONS AT FIGURE #1.
- REMOVE THE AN365-524A NUTS, AN960-516 WASHERS, AND AN45-24 EYE-BOLTS FROM THE STABILATOR MAIN SPAR. MAKE SURE THE COMPRESSION SLEEVES DO NOT FALL OUT.
- TAKE THE MAIN SPAR AREA PLATES TT10-107 AND SLIDE THEM OVER THE EYE-BOLTS FROM BEFORE. INSERT THIS ASSEMBLY INTO THE SPAR AND TIGHTEN WITH THE SAME WASHERS AND NUTS. MAKE SURE THAT THE TOP AND BOTTOM OF EACH AREA PLATE IS PARALLEL TO THE SPAR.
- MATCH DRILL THE HOLES IN EACH AREA PLATE WITH A #30 DRILL BIT. TO MAKE SURE YOU ONLY DRILL INTO THE SPAR AND NOT THE ROUND DOUBLER, USE A 1/4" STOP ON THE BIT.
- REMOVE THE EYE-BOLTS, WASHERS, AND NUTS.
- USE URALANE AND (4) SK43BS RIVETS TO ATTACH EACH AREA PLATE TO THE SPAR.
- REINSTALL THE EYE-BOLTS, WASHERS, AND NUTS. THEN, PATCH THE SKIN, USING PANELS FOR ALUMINUM OR STRIPS FOR FABRIC.
- REATTACH THE STABILATOR TO THE AIRCRAFT IN THE OPPOSITE ORDER THAT YOU DISASSEMBLED IT.

TITAN AIRCRAFT SUPPLY
 1419 STATE ROUTE 45 SOUTH
 AUSTINBURG, OHIO 44010

DETAIL NAME STABILATOR MAIN SPAR AREA PLATE INSTALLATION	
SCALE N/A	PART NO.
ASSEMBLY NAME	
PART NO.	DRAWING NO.
DRAWING NO.	B 10-INS-1466-A

DRAWN B. HARE	DATE 1/29/10
CHECKED R. INGLE	DATE 7/21/10
APPROVED K. BROOKS	DATE 7/22/10

THIS DOCUMENT PROPRIETARY TO TITAN AIRCRAFT, AND IS NOT TO BE USED, CIRCULATED, REPRODUCED, COPIED, OR DISCLOSED IN ANY MANNER WITHOUT PRIOR WRITTEN PERMISSION OF AN AUTHORIZED OFFICIAL OF TITAN AIRCRAFT.