

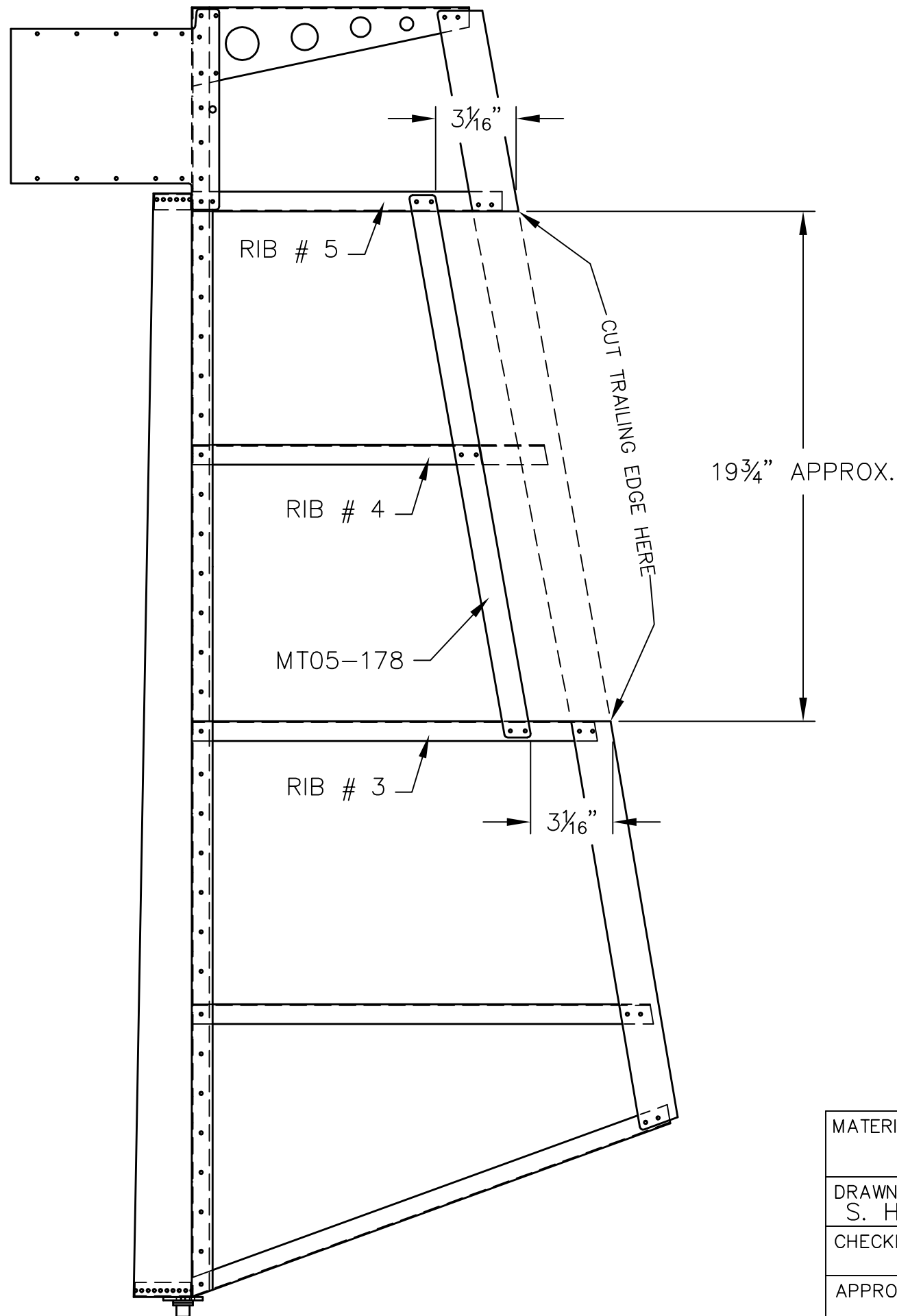

THIS DOCUMENT PROPRIETARY TO TITAN AIRCRAFT, AND IS NOT TO BE USED, CIRCULATED, REPRODUCED, COPIED, OR DISCLOSED IN ANY MANNER WITHOUT PRIOR WRITTEN PERMISSION OF AN AUTHORIZED OFFICIAL OF TITAN AIRCRAFT.



REVISIONS				
E.C. NO.	REV.	DESCRIPTION	BY	DATE
	A	DRAWING RELEASED	SH	10/05

NOTE:

- MEASURE & MARK 3 1/16" IN FROM TRAILING EDGE ON RIBS 3, 4, & 5.
- DRILL EXISTING RIVETS OUT OF TRAILING EDGE ON RIB #4.
- CUT TRAILING EDGE FROM TOP OF RIB #3 TO THE BOTTOM OF RIB #5, (APPROX. 19 3/4" OF TRAILING EDGE WILL BE REMOVED, SAND SHARP EDGES.)
- CUT RIB #4 TO 3 1/16" MARK FROM TRAILING EDGE.
- ADD MT05-178 BETWEEN RIBS 3 & 5 MAKING SURE FLANGES LINE UP WITH 3 1/16" MARKS, THEN MATCH DRILL WITH #30 DRILL & RIVET (12) PLACES (SD42BS).

		TITAN AIRCRAFT SUPPLY 1419 STATE ROUTE 45 SOUTH AUSTINBURG, OHIO 44010	
		DETAIL NAME	
MATERIAL		SCALE N/A	PART NO.
DRAWN S. HENDERSON	DATE 10/17/05	ASSEMBLY NAME RUDDER TRIM TAB INSTRUCTIONAL	
CHECKED R.I.	DATE 11/2/05	PART NO.	DRAWING NO.
APPROVED J.W.	DATE 11/2/05	DRAWING NO. B T51-05-INS-1270-A	

MATERIAL	
DRAWN S. HENDERSON	DATE 10/17/05
CHECKED R.I.	DATE 11/2/05
APPROVED J.W.	DATE 11/2/05