

THIS DOCUMENT PROPRIETARY TO TITAN AIRCRAFT, AND IS NOT TO BE USED, CIRCULATED, REPRODUCED, COPIED, OR DISCLOSED IN ANY MANNER WITHOUT PRIOR WRITTEN PERMISSION OF AN AUTHORIZED OFFICIAL OF TITAN AIRCRAFT.

REVISIONS				
E.C. NO.	REV.	DESCRIPTION	BY	DATE
	A	DRAWING RELEASED	CE	12/03
0076	B	SIMPLIFIED DRAWING	CE	3/04
0783	C	DRAWING RE-DESIGNED	SH	10/08

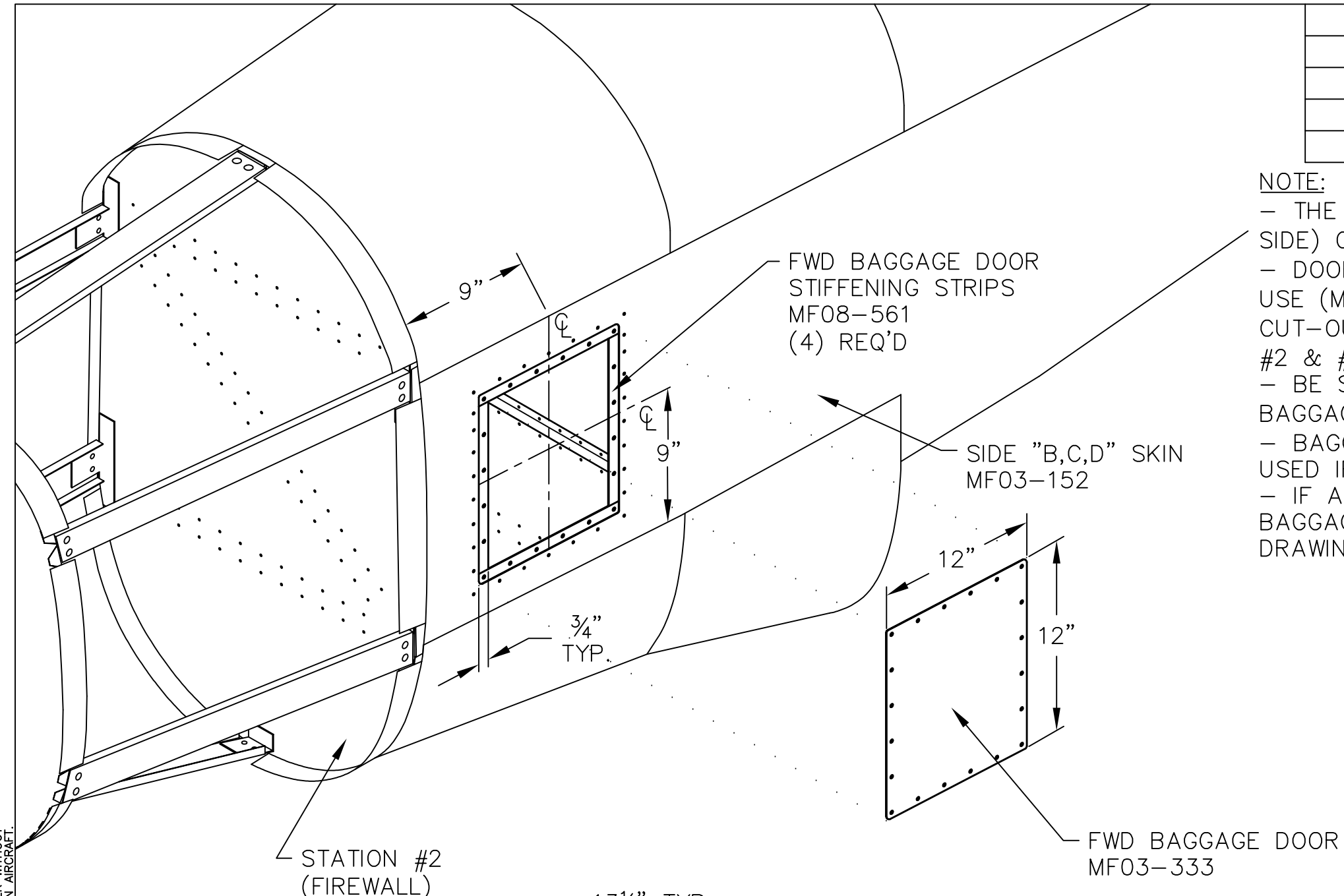

NOTE:

- THE BAGGAGE DOOR SHOULD BE ON THE LEFT SIDE (PORT SIDE) OF THE AIRCRAFT ONLY!
- DOOR SIZE SHOULD BE NO BIGGER THAN 12" X 12". YOU CAN USE (MF03-333) AS A PATTERN FOR THE FWD BAGGAGE DOOR CUT-OUT ON "B,C,D" SIDE SKIN (MF03-152) BETWEEN STATIONS #2 & #3. (AS SHOWN)
- BE SURE TO ADD A RADIUS TO THE CORNERS OF THE BAGGAGE DOOR & OPENING. (DO NOT LEAVE SHARP CORNERS)
- BAGGAGE DOOR STIFFENING STRIPS (MF08-561) ARE ONLY USED IF BAGGAGE AREA IS NOT GOING TO BE DOUBLE WALLED.
- IF AIRCRAFT IS EQUIPPED WITH A V6 POWER PLANT. THE FWD BAGGAGE AREA WILL NEED TO BE DOUBLER WALLED. REFER TO DRAWING T51-06-INS-1401 FOR INSTRUCTIONS.

****OPTIONAL DOOR ATTACHMENT METHODS****

- RIVETS
- SCREWS AND NUT PLATES
- 1/4" TURN FASTENERS (MH08-116)
- HINGES AND LATCHES

- IF GOING TO INSTALL FWD BAGGAGE DOOR AND NOT USING A V6 POWER PLANT, MATERIALS SHOWN ON THIS DRAWING IS ALL THAT IS NEEDED.

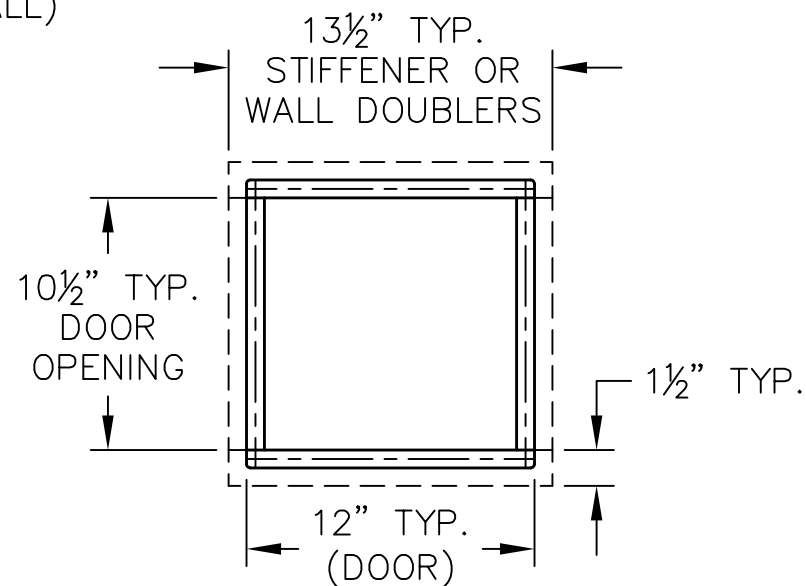

DRAWN C. EMERY	DATE 12/17/03
CHECKED	DATE
APPROVED	DATE

 TITAN AIRCRAFT SUPPLY 1419 STATE ROUTE 45 SOUTH AUSTINBURG, OHIO 44010	
DETAIL NAME	FWD BAGGAGE DOOR INSTRUCTIONAL
SCALE 1/8"=1"	PART NO.
OPTION	
PART NO.	DRAWING NO. F25
DRAWING NO. B T51-03-INS-0971-C	