

- STUB RIB, INNER FLAP BRACKET #1-RH (MW02-39)
- STUB RIB, INNER FLAP BRACKET #1-LH (MW02-40)
- STUB RIB, INNER FLAP BRACKET #2-RH (MW02-41)
- STUB RIB, INNER FLAP BRACKET #2-LH (MW02-42)

- INBOARD FLAP BRACKET MW02-22
- INBOARD FLAP BRACKET WEB MW02-213
- FLAP HINGE SPACER (2) MW03-249

- AN4-12A BOLT
- AN960-416 WASHER
- AN365-428 LOCK NUT

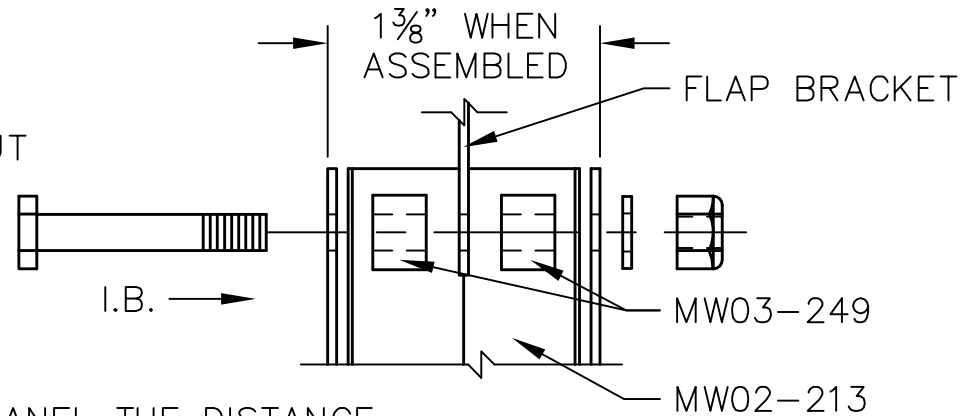

REVISIONS				
E.C. NO.	REV.	DESCRIPTION	BY	DATE
0372	C	NUT & WASHER CHNG'D	SH	11/06
0918	D	BOLT CHANGED	SH	3/09
1015	E	FOR EARLY STYLE BRACKETS	BH	2/10

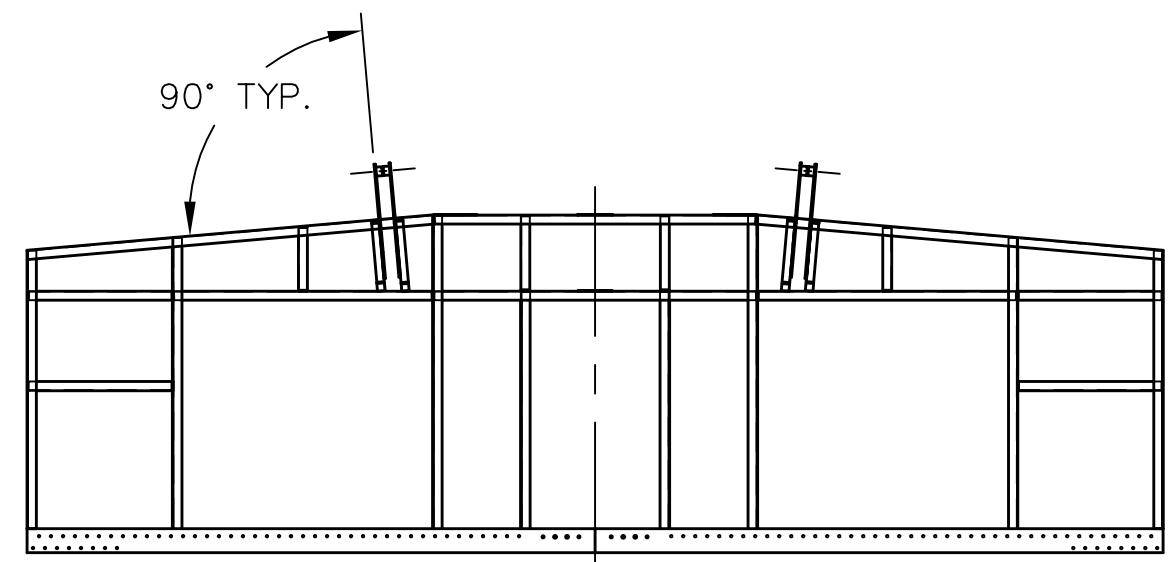
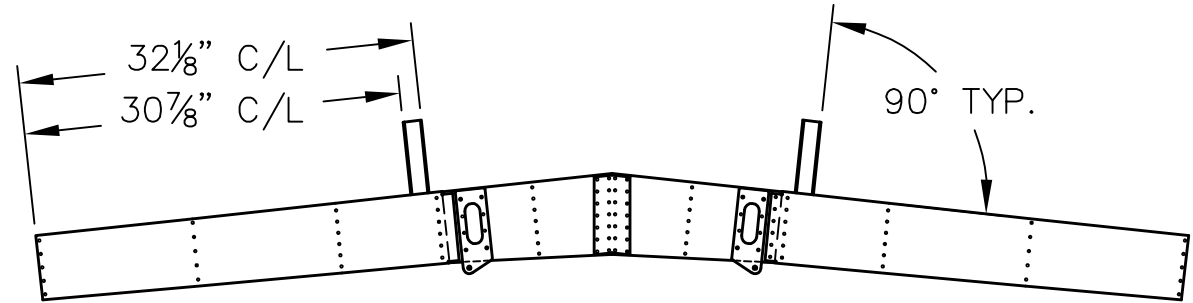

**NOTES:**

- MOUNT AILERON & FLAP ON OUTER WING PANEL THE DISTANCE BETWEEN FLAP AND AILERON SHOULD BE APPROX. 1/8" TO 3/16".
- PLACE FLAP BRACKET #1 STUB RIB INTO THE CENTER SECTION FIRST. INSERT THE INBOARD FLAP BRACKET INTO THE CENTER SECTION. THEN USING THE 1/2" NYLON SPACERS BOLT THE FLAP BRACKETS AND FLAP HINGE TOGETHER TIGHTLY AS SHOWN. PLACE INNER FLAP BRACKET #2 STUB RIB IN PLACE.
- MAKING SURE THAT THE FLAP BRACKETS ARE IN POSITION AGAINST THE AFT SPAR SLIDE #1 AND #2 FLAP STUB RIB INTO POSITION NEXT TO FLAP BRACKETS.
- TRACE THE BRACKETS POSITION ONTO THE STUB RIBS.
- REMOVE THE STUB RIBS AND ASSEMBLY.
- MATCH DRILL INNER FLAP BRACKET #1 & #2 STUB RIBS (MW02-39, MW02-40, MW02-41 & MW02-42) TO INBOARD FLAP BRACKETS TRACING.
- BE SURE TRAILING EDGES ARE FLUSH AND CENTERED AS SHOWN BELOW.
- CLECO ONLY AT THIS TIME. \*\*DO NOT RIVET UNTIL PARTS ARE ASSEMBLED INSIDE THE CENTER SECTION.
- MAKE SURE ALL PARTS THAT WILL NEED BONDED ARE SANDED AND READY FOR BONDING. ASSEMBLE THE INNER FLAP BRACKET (MW02-39 OR MW02-40) AND STUB RIBS INSIDE THE CENTER SECTION AS SHOWN.

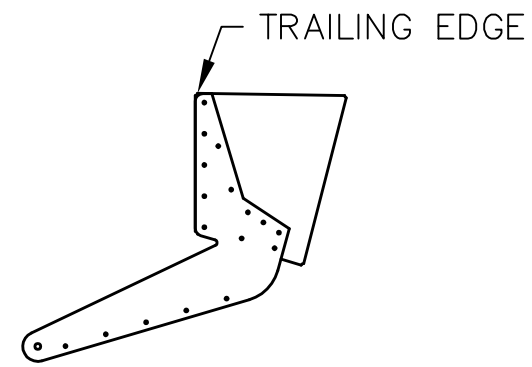

**TITAN AIRCRAFT SUPPLY**  
 1419 STATE ROUTE 45 SOUTH  
 AUSTINBURG, OHIO 44010

DETAIL NAME		INBOARD FLAP BRACKET INSTALLATION		
SCALE	N/A	PART NO.		
ASSEMBLY NAME		FOR A/C SERIAL # 151 & EARLIER		
PART NO.		DRAWING NO. CS13		
DRAWING NO.		B T51-03-INS-0650-E		

DRAWN	K. LIPLIN	DATE	3/13/03
CHECKED	R. INGLE	DATE	2/16/10
APPROVED	K. BROOKS	DATE	2/16/10

THIS DOCUMENT PROPRIETARY TO TITAN AIRCRAFT, AND IS NOT TO BE USED, CIRCULATED, REPRODUCED, COPIED, OR DISCLOSED IN ANY MANNER WITHOUT PRIOR WRITTEN PERMISSION OF AN AUTHORIZED OFFICIAL OF TITAN AIRCRAFT.