

NOTES:

- INSTALL "O" RING (MG02-122) ON THE PISTON (MG01-27).
- ASSEMBLE THE PISTON, UPPER OLEO SLEEVE AND PISTON PIN TO THE OLEO STRUT.
- SLIDE THE OLEO SPACER (MG02-101) ONTO THE OLEO STRUT.
- SLIDE THE ASSEMBLED OLEO STRUT INTO THE UPPER MAIN GEAR WELDMENT.
- INSTALL "O" RING (MG02-124) ONTO THE LOWER OLEO SLEEVE AND "O" RING (MG02-123) INTO THE OLEO SLEEVE.
- SLIDE THE ASSEMBLED LOWER OLEO SLEEVE OVER THE OLEO STRUT AND INTO THE UPPER MAIN GEAR WELDMENT.
- INSTALL THE 2" SNAP RING (MG02-110)
- ** CAUTION **** THIS SNAP RING HOLDS THE PRESSURIZED OLEO TOGETHER, THE SNAP RING MUST BE SEATED CORRECTLY. IF NOT, THE OLEO MAY BLAST APART WHEN THE AIRCRAFT WEIGHT IS OFF THE LANDING GEAR. (AFTER TAKEOFF).
- TO SERVICE THE STRUT, REMOVE THE OLEO VALVE, COLLAPSE THE STRUT UNTIL IT STOPS. ATTACH ONE END OF A HOSE TO THE VALVE FITTING, THE OTHER END IMMERSED IN A CAN OF MIL-5606 HYDRA. FLUID (OR EQUAL). EXTEND THE STRUT TO FULL EXTENSION, HYDRA. FLUID WILL BE DRAWN INTO THE STRUT.
- EXTEND AND COLLAPSE THE STRUT SEVERAL TIMES UNTIL THERE ARE NO AIR BUBBLES IN THE CAN. WITH STRUT COLLAPSED, EXTEND UNTIL 1" OF STRUT IS VISIBLE, REMOVE HOSE AND REINSERT THE OLEO VALVE FITTING.
- EXTEND THE STRUT AND REPLACE THE OLEO VALVE. PRESSURIZE THE STRUT WITH NITROGEN OR COMPRESSED AIR TO 165 TO 185 PSI.
- WITH THE WEIGHT OFF THE GEAR, CHECK THE PRESSURE AND ADD AIR IF NECESSARY.

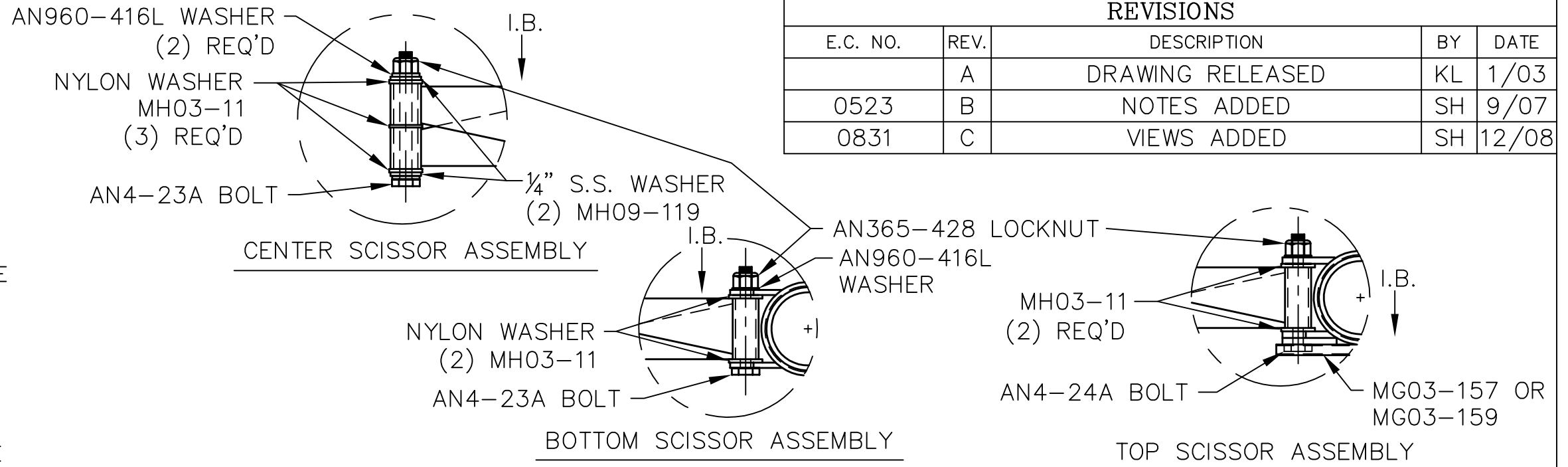

REVISIONS				
E.C. NO.	REV.	DESCRIPTION	BY	DATE
	A	DRAWING RELEASED	KL	1/03
0523	B	NOTES ADDED	SH	9/07
0831	C	VIEWS ADDED	SH	12/08

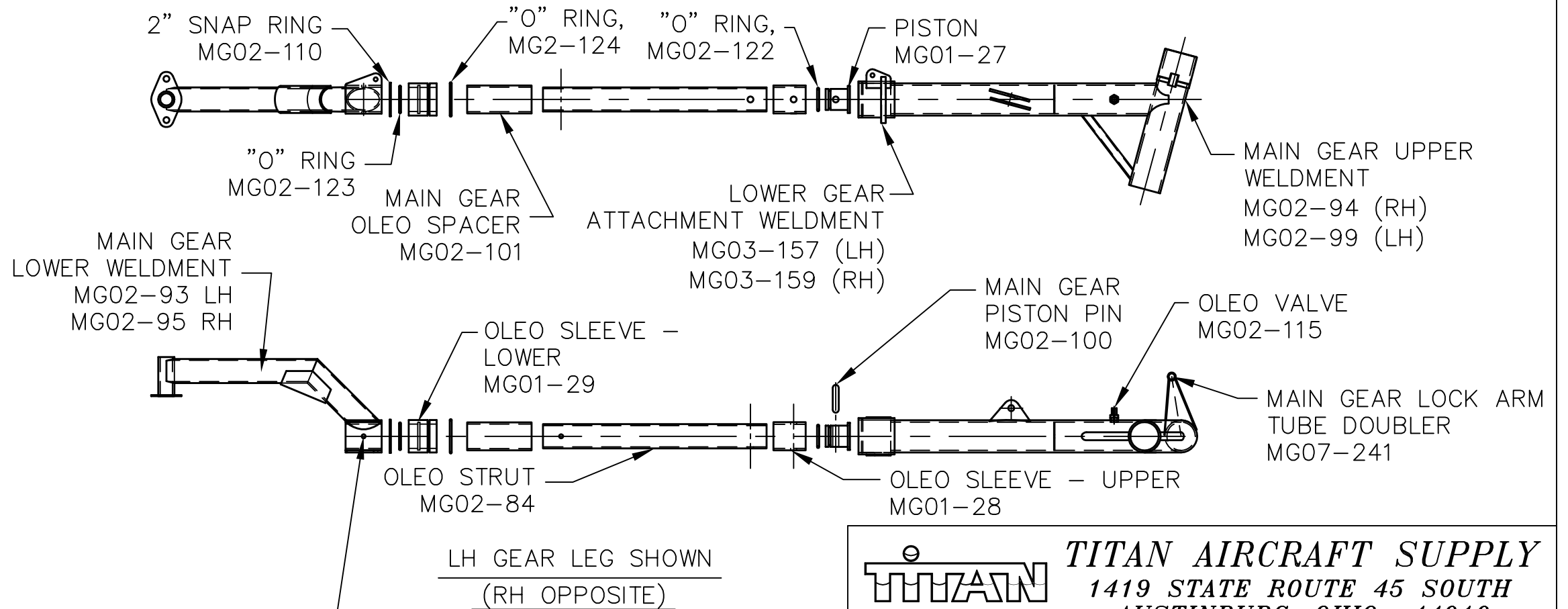

AN4-21A BOLT
AN960-416 WASHER
AN365-428 LOCKNUT

TITAN AIRCRAFT SUPPLY
1419 STATE ROUTE 45 SOUTH
AUSTINBURG, OHIO 44010

DETAIL NAME		OLEO EXPLODED VIEW	
SCALE 1/8"=1"	PART NO.		
ASSEMBLY NAME			
PART NO.	DRAWING NO. LG1		
DRAWING NO.		B T51-03-INS-0589-C	

DRAWN K. LIPLIN	DATE 1/22/03
CHECKED R. INGLE	DATE 2/20/09
APPROVED K. BROOKS	DATE 10/6/09

THIS DOCUMENT PROPRIETARY TO TITAN AIRCRAFT, AND IS NOT TO BE USED, CIRCULATED, REPRODUCED, COPIED, OR DISCLOSED IN ANY MANNER WITHOUT PRIOR WRITTEN PERMISSION OF AN AUTHORIZED OFFICIAL OF TITAN AIRCRAFT.