

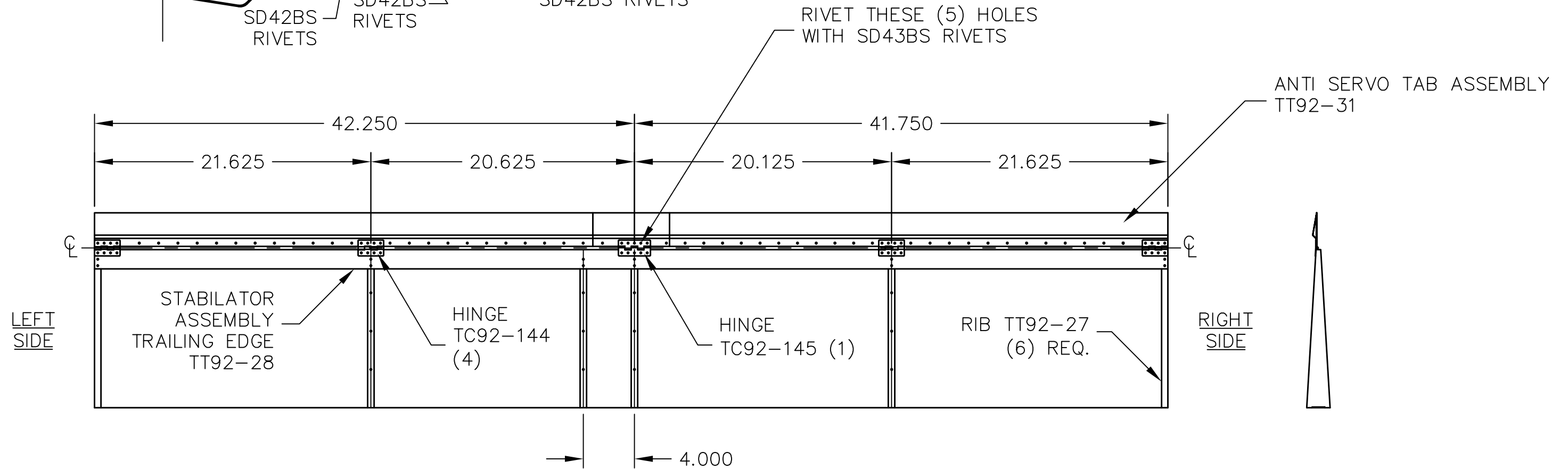

| REVISIONS | | | | |
|-----------|------|--------------------|----|-------|
| E.C. NO. | REV. | DESCRIPTION | BY | DATE |
| | A | DRAWING RELEASED | JP | 10/92 |
| 1537 | B | UPDATED DRAWING | KL | 11/00 |
| 2231 | D | CHANGED DIMENSIONS | BH | 4/10 |



BOTTOM VIEW OF STABILATOR

NOTES:

- ALL DIMENSIONS ARE INCHES.
- CENTER RIB CENTERLINE IS OFFSET TO THE RIGHT BY .250.
- LOCATE LARGER HINGE ON CENTER OF ANTI SERVO TAB.
- (2) OUTER HINGES MOUNT FLUSH WITH EDGE OF ANTISERVO TAB.
- BARRELS OF HINGES SHOULD HAVE MINIMUM 1/32 OF FREE SPACE ON EACH SIDE. THIS PREVENTS MOVING HINGE PARTS FROM RIDING ON THE STABILATOR AND ANTI SERVO TAB.
- TO ENSURE SMOOTH ANTI SERVO TAB CONTROL, HINGE BARRELS MUST BE POSITIONED ON CENTER WITH EACH OTHER.
- DRILL MOUNTING HOLES WITH #30 (Ø.1285) DRILL.
- BOND HINGES TO ANTI SERVO TAB WITH EPOXY AND RIVET WITH SD41BS RIVETS (Ø.125 X .203 LONG) AND SD43BS RIVETS (Ø.125 X .328 LONG) WHERE SHOWN.
- DO NOT PERMANENTLY INSTALL ANTI SERVO TAB TO STABILATOR UNTIL THE STITS FABRIC HAS BEEN APPLIED TO THE STABILATOR.

| | | | | | |
|---|--|---------------|--|----------------------------|--|
|  TITAN AIRCRAFT SUPPLY 1419 STATE ROUTE 45 SOUTH AUSTINBURG, OHIO 44010 | | DETAIL NAME | | 7' ANTI SERVO TAB ASSEMBLY | |
| | | SCALE 1/8"=1" | | PART NO. | |
| DRAWN | | DATE | | ASSEMBLY NAME | |
| J. PRESTON | | 10/19/92 | | TORNADO I & II | |
| CHECKED | | DATE | | PART NO. | |
| R. INGLE | | 4/14/10 | | DRAWING NO. | |
| APPROVED | | DATE | | DRAWING NO. | |
| K. BROOKS | | 4/26/10 | | B 92-INS-0188-D | |

THIS DOCUMENT PROPRIETARY TO TITAN AIRCRAFT, AND IS NOT TO BE USED, CIRCULATED, REPRODUCED, COPIED, OR DISCLOSED IN ANY MANNER WITHOUT PRIOR WRITTEN PERMISSION OF AN AUTHORIZED OFFICIAL OF TITAN AIRCRAFT.