

**CAUTION!**

- WHEN DRILLING THE RIBS TO THE MAIN SPAR, DRILL THE 2ND HOLE (MARKED WITH \*) FIRST AND CLECO IN PLACE. DOUBLE CHECK DIMENSIONS FOR OUTBOARD SPAR CAP HOLES BEFORE DRILLING.
- WHEN DRILLING THE OUTSIDE HOLES ON THE RIB FLANGES, BE SURE THAT RIBS 2,3, & 4 ARE DRILLED AT  $\frac{3}{4}$ " IN FROM THE EDGE & RIB 5,6, & 7 ARE DRILLED  $\frac{1}{2}$ " IN FROM THE EDGE. (THIS IS TO KEEP THE HOLES NEAR THE CENTER OF THE SPAR CAPS LEGS. IT IS IMPORTANT THAT THESE HOLES BE DRILLED IN THE CORRECT LOCATIONS & NO ADDITIONAL HOLES ARE DRILLED IN THE SPAR CAP.)

REVISIONS				
E.C. NO.	REV.	DESCRIPTION	BY	DATE
	E	NOTES CHANGED	SH	11/07
0865	F	NOTES ADDED	SH	2/09
1098	G	DIMENSIONS CHANGED	BH	9/10

RIVET LOCATIONS FOR RIB FORWARD FLANGES

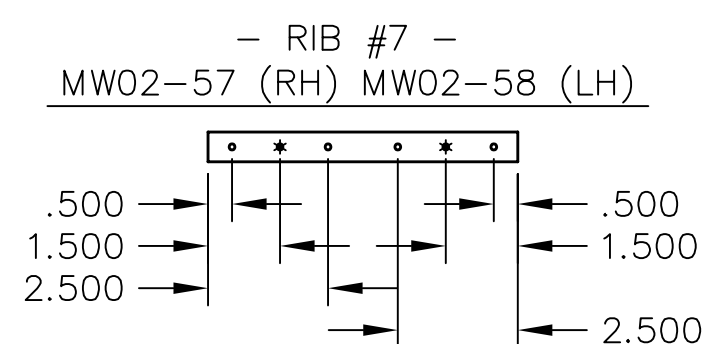
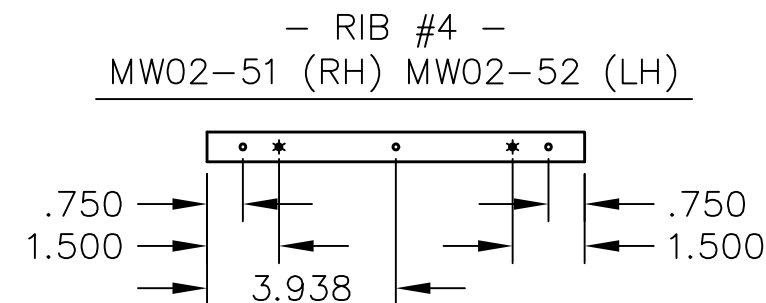
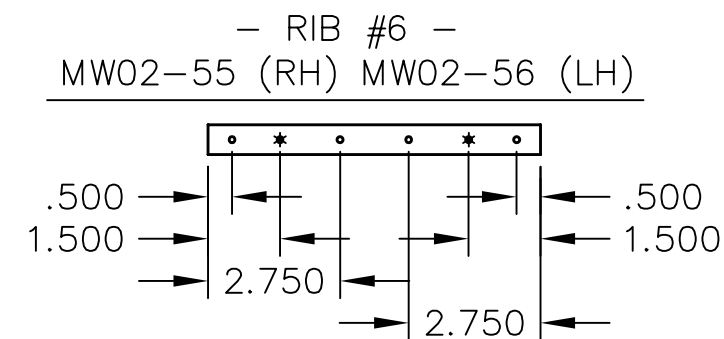
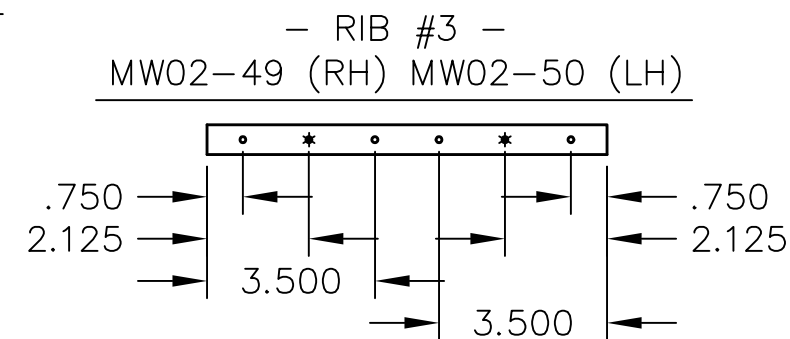
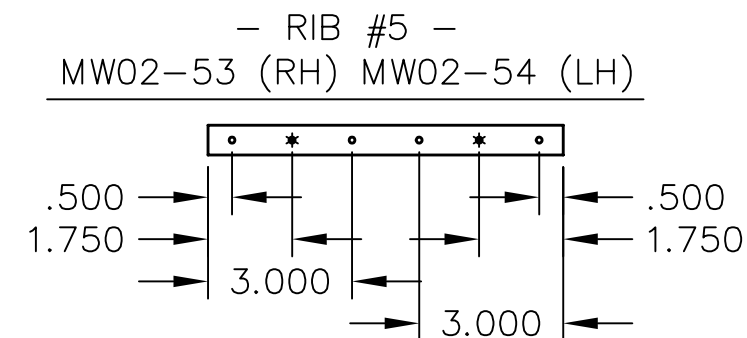
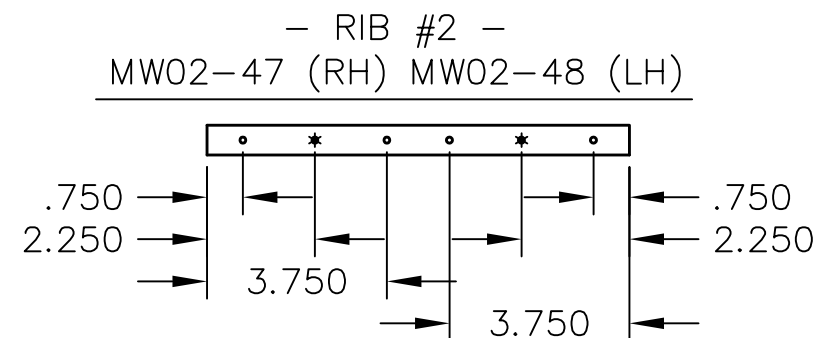
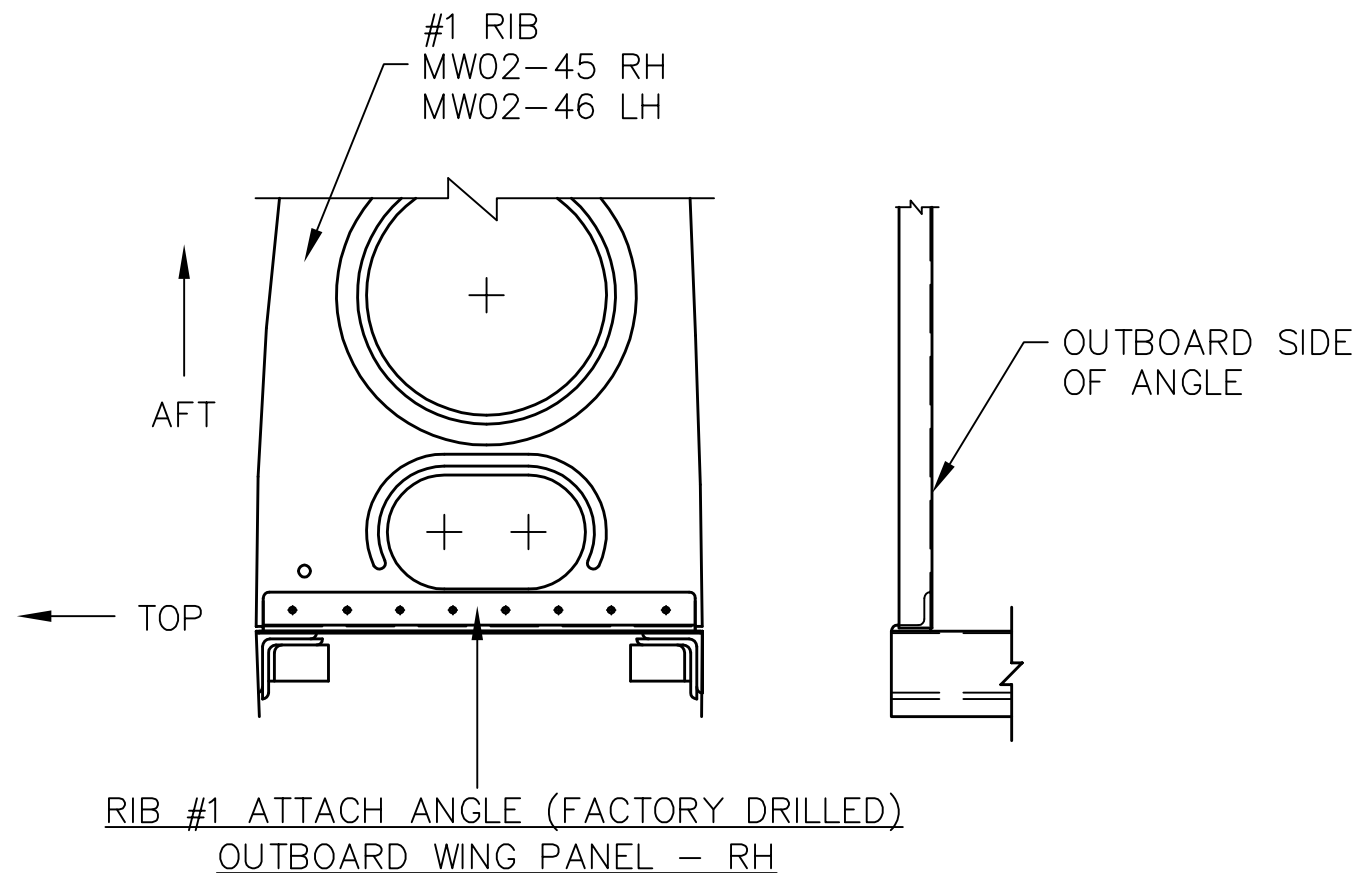

NOTES:

- RIB #1 ATTACHES TO THE  $\frac{1}{8}$ " THICK ATTACH ANGLE (INSTALLED BY FACTORY) AT THE ROOT END OF MAIN SPAR, BE SURE RIB #1 IS ATTACHED TO THE OUTBOARD SIDE OF THIS ANGLE.
- RIBS #2 THRU #7 ATTACH TO THE MAIN SPAR BY THEIR FWD FLANGES.



**TITAN AIRCRAFT SUPPLY**  
1419 STATE ROUTE 45 SOUTH  
AUSTINBURG, OHIO 44010

DETAIL NAME OUTER WING PANEL RIB DRILL PATTERNS

DRAWN K. LIPLIN	DATE 8/20/02	SCALE 1/4"=1"	PART NO.
CHECKED K. BROOKS	DATE 9/27/10	ASSEMBLY NAME	
APPROVED B. KOLENO	DATE 12/9/10	PART NO.	DRAWING NO. W1
		DRAWING NO. <b>B T51-02-INS-0385-G</b>	